

PT. SINERGI GLOBAL AUTOMASI

Grand Galaxy City RSK 6/67

Jl. Boulevard Raya, Jakasetia 17147 - Bekasi Selatan

(021) 8275 5723 | (021) 8267 8558

sales@negai.co.id | www.negai.co.id



APEX DYNAMICS, INC.

PLANETARY GEARBOX NEW GENERATION P-SERIES

PEII / PGII / PAII / PSII / PNII / PD / PL

PEIIR / PGIIR / PAIIR / PSIIR / PNIIR / PDR / PLR



New Generation P Series

▶ Features:

Economic

High efficiency

Low noise

Reduced backlash

Optimized Inertia moment

Limited temperature rise

Long service life

Flexible mounting diameters

Minimized size and weight

The perfect servo planetary gearbox !
The brand new APEX PII / PIIIR series.
The PII / PIIIR series is an economic high precision planetary gearbox with excellent performance and quality. Our innovative PII / PIIIR series design features minimal size, light weight and high efficiency.



PEII



PEIIR



PGII



PGIIR



PAII



PAIIR



PSII



PSIIR



PNII



PNIIR

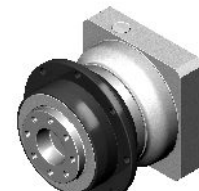

PD



PDR



PL



PLR

ORDERING CODE

PEII 090 – **010⁽¹⁾** – **()⁽²⁾** / **MOTOR**

PEIIR 090 – **010⁽¹⁾** – **()⁽²⁾** / **MOTOR**

Motor Type :
Manufacturer and Model

Ratio⁽¹⁾:

1-stage: 3, 4, 5, 7, 9⁽³⁾, 10

2-stage: 12⁽⁵⁾, 15, 16, 20, 25, 30, 35, 40, 50, 70, 81⁽³⁾, 100

3-stage⁽⁴⁾: 120, 160, 200, 280, 350, 500, 700, 1000

Gearbox Size:

PEII : PEII 050, PEII 070, PEII 090, PEII 120, PEII 155

PGII : PGII 040, PGII 060, PGII 080, PGII 120, PGII 160

PAII : PAII 042, PAII 060, PAII 090, PAII 115, PAII 142

PSII : PSII A, PSII B, PSII C, PSII D, PSII E

PNII : PNII 017, PNII 023, PNII 034, PNII 042, PNII 056

PD : PD 053, PD 064, PD 090, PD 110

PL : PL 070, PL 090, PL 120,

Ordering Example : PEII 090 - 010 / SIEMENS 1FT6 041 - 4AF71
PAII 090 - 010 - S1 / SIEMENS 1FT6 041 - 4AF71

Gearbox Size:

PEIIR : PEIIR 050, PEIIR 070, PEIIR 090, PEIIR 120, PEIIR 155

PGIIR : PGIIR 040, PGIIR 060, PGIIR 080, PGIIR 120, PGIIR 160

PAIIR : PAIIR 042, PAIIR 060, PAIIR 090, PAIIR 115, PAIIR 142

PSIIR : PSIIR A, PSIIR B, PSIIR C, PSIIR D, PSIIR E

PNIIR : PNIIR 017, PNIIR 023, PNIIR 034, PNIIR 042, PNIIR 056

PDR : PDR 053, PDR 064, PDR 090, PDR 110

PLR : PLR 070, PLR 090, PLR 120

Ordering Example : PEIIR 090 - 010 / SIEMENS 1FT6 041 - 4AF71
PAIIR 090 - 010 - S1 / SIEMENS 1FT6 041 - 4AF71

(1) Ratio ($i = N_{in} / N_{out}$).

(2) S1 = Smooth Output Shaft. S1 shaft is only provided for PAII / PAIIR series.

S2 = Output Shaft with Key. This is the standard shaft for PII / PIIR gearbox.

(3) Only provided for PSII/PSIIR and PAII/PAIIR series.

(4) Only provided for PGII and PGIIR series.

(5) Only provided for PL and PLR series.

PEII / PEIIR Gearbox Performance

Model No.	Stages	Ratio ⁽¹⁾	Type	PEII 050	PEII 070	PEII 090	PEII 120	PEII 155					
				PEIIR 050	PEIIR 070	PEIIR 090	PEIIR 120	PEIIR 155					
Nominal Output Torque T_{2N}	1	3	All	16	42	110	217	430					
		4		16	42	113	223	440					
		5		15	40	118	220	435					
		7		12	35	96	198	366					
		10		10	27	68	155	295					
	2	15		15	40	109	213	424					
		16		16	42	116	228	452					
		20		16	42	116	230	454					
		25		15	40	123	228	450					
		30		15	40	108	212	422					
		35		12	35	100	206	382					
		40		16	43	117	232	459					
		50		15	40	123	228	450					
		70		12	35	100	206	382					
		100		10	27	70	162	308					
		Emergency Stop Torque T_{2NOT}		Nm	1,2	3~100	All					3 times T_{2N}	
Max. Acceleration Torque T_{2B}	Nm	1,2	3~100	All					$T_{2B} = 60\%$ of T_{2NOT}				
No Load Running Torque ⁽⁴⁾	1	3~10	PEII	0.05	0.10	0.40	0.80	2.50					
			PEIIR	0.10	0.15	0.45	0.85	2.55					
	2	15~100	PEII	0.05	0.10	0.30	0.40	0.80					
			PEIIR	0.10	0.15	0.35	0.45	0.85					
Backlash ⁽²⁾	1	3~10	PEII	≤ 8	≤ 7	≤ 6	≤ 6	≤ 6					
			PEIIR	≤ 12	≤ 11	≤ 10	≤ 10	≤ 10					
	2	15~100	PEII	≤ 10	≤ 9	≤ 8	≤ 8	≤ 8					
			PEIIR	≤ 14	≤ 13	≤ 12	≤ 12	≤ 12					
Torsional Rigidity	Nm/arcmin	1,2	3~100	All	0.9	2.2	8	12	16				
Nominal Input Speed n_{1N}	rpm	1,2	3~100	All	4,500	4,000	3,600	3,600	2,500				
Max. Input Speed n_{1B}	rpm	1,2	3~100	All	8,000	6,000	6,000	4,800	3,600				
Max. Radial Load F_{2rB} ⁽³⁾	N	1,2	3~100	All	810	1,150	1,530	3,260	4,550				
Max. Axial Load F_{2aB} ⁽³⁾	N	1,2	3~100	All	405	575	765	1,630	2,275				
Operating Temp	°C	1,2	3~100	All	0° C ~ +90° C								
Degree of Gearbox Protection		1,2	3~100	All	IP65								
Lubrication		1,2	3~100	All	Synthetic lubrication grease								
Mounting Position		1,2	3~100	All	All directions								
Running Noise ⁽⁴⁾	dB(A)	1,2	3~100	PEII	≤ 60	≤ 62	≤ 64	≤ 66	≤ 68				
				PEIIR	≤ 70	≤ 72	≤ 74	≤ 75	≤ 77				
Max. bending moment based on the gearbox input flange M_b ⁽⁵⁾	Nm	1,2	3~100	PEII	5	12	22	45	54				
				PEIIR	3	6	10	17	19				
Efficiency η	%	1	3~10	PEII	$\geq 97\%$								
				PEIIR	$\geq 93\%$								
		2	15~100	PEII	$\geq 94\%$								
				PEIIR	$\geq 90\%$								

(1) Ratio ($i = N_{in} / N_{out}$).(2) Backlash is measured at 2% of Nominal Output Torque T_{2N} .

(3) Applied to the output shaft center at 100 rpm.

(4) The dB values are measured by gearbox with ratio 10 (1-stage) or ratio 100 (2-stage), no loading at 3,000 RPM or at the respective Nominal Input Speed by bigger model size.

By lower ratio and/or higher RPM, the noise level could be 3 to 5 dB higher.

(5) Max. motor weight* (kg) = $\frac{0.1 \times Mb}{\text{motor length (m)}}$

*with symmetrically distributed motor weight

*with horizontal and stationary mounting

(6) 5 years warranty.

PEII Gearbox Inertia

Model No.	PEII 050		PEII 070		PEII 090		PEII 120		PEII 155	
$\varnothing^{(A)}$ (C3)	1-stage	2-stage	1-stage	2-stage	1-stage	2-stage	1-stage	2-stage	1-stage	2-stage
8	0.10	0.10	0.12	0.10	-	-	-	-	-	-
11	0.16	0.16	0.19	0.16	-	-	-	-	-	-
14	-	-	0.22	0.20	0.36	0.24	-	-	-	-
19	-	-	1.53	1.51	1.70	1.58	2.20	1.73	-	2.18
24	-	-	-	-	2.24	2.12	2.74	2.27	4.52	2.73
28	-	-	-	-	2.68	2.55	3.17	2.70	4.94	3.15
32	-	-	-	-	-	-	7.77	7.30	9.70	7.91
35	-	-	-	-	-	-	10.80	10.30	12.80	11.00
38	-	-	-	-	-	-	14.00	13.50	16.00	14.20
42	-	-	-	-	-	-	-	-	24.50	-

PEIIR Gearbox Inertia

Model No.	PEIIR 050		PEIIR 070		PEIIR 090		PEIIR 120		PEIIR 155	
$\varnothing^{(A)}$ (C3)	1-stage	2-stage	1-stage	2-stage	1-stage	2-stage	1-stage	2-stage	1-stage	2-stage
8	0.18	0.18	0.36	0.36	-	-	-	-	-	-
11	0.20	0.20	0.39	0.39	-	-	-	-	-	-
14	-	-	0.43	0.43	1.87	1.87	-	-	-	-
19	-	-	1.24	1.24	2.67	2.67	6.80	6.80	-	13.57
24	-	-	-	-	2.97	2.97	7.10	7.10	13.87	13.87
28	-	-	-	-	3.47	3.47	7.59	7.59	14.36	14.36
32	-	-	-	-	-	-	10.56	10.56	17.33	17.33
35	-	-	-	-	-	-	11.97	11.97	18.74	18.74
38	-	-	-	-	-	-	13.95	13.95	20.79	20.79
42	-	-	-	-	-	-	-	-	26.54	-

Permitted Radial And Axial Loads^(B)

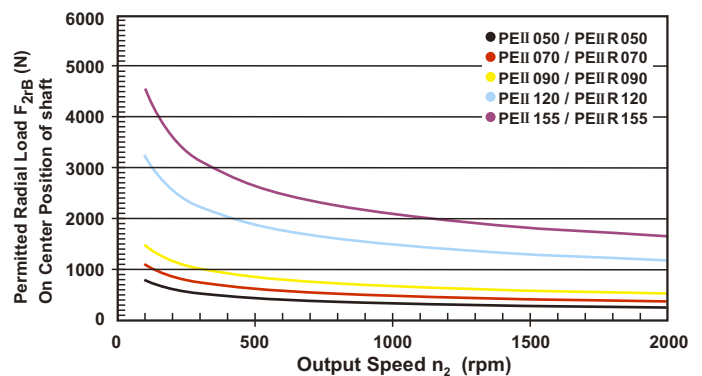
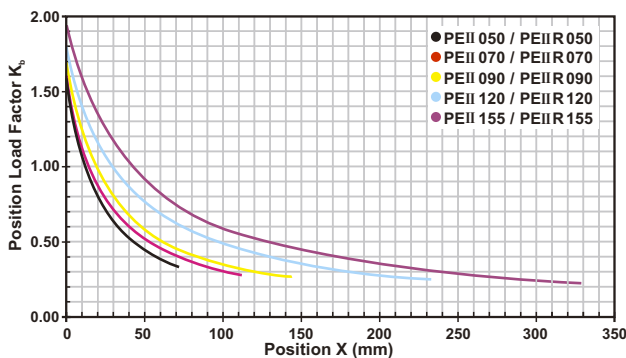

If radial force F_{zr} is not exerted on the center of the output shaft $X < 1/2 L$ or $X > 1/2 L$, the permitted radial and axial loads can be calculated by the position load factor K_s on the above diagram.

Permitted radial load F_{zr} on center of output shaft $X = 1/2 L$ for various output speeds.

(A) \varnothing = Input shaft diameter.

(B) Permitted loading values on the output shaft. Please refer to P. 33 glossary.

PEII Series Dimension

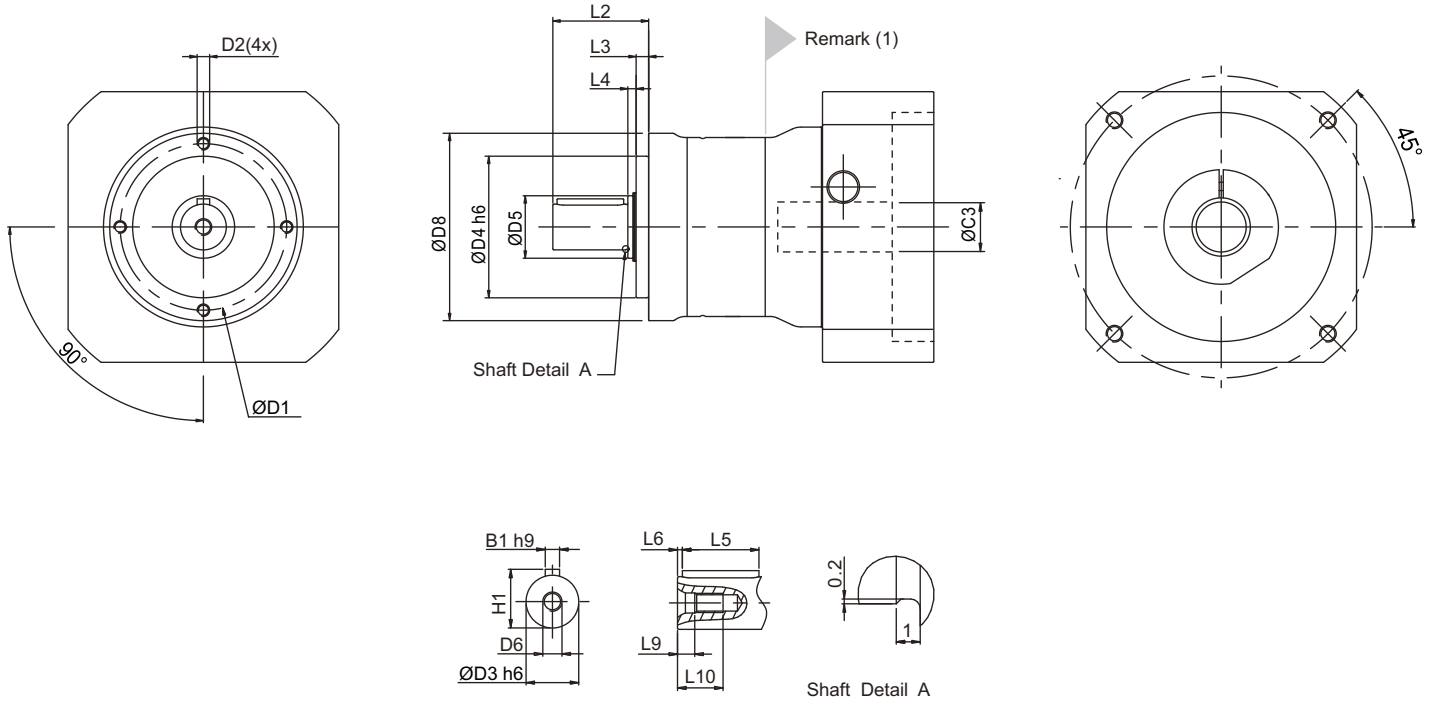

Dimension	PEII 050		PEII 070		PEII 090		PEII 120		PEII 155	
	1-stage	2-stage	1-stage	2-stage	1-stage	2-stage	1-stage	2-stage	1-stage	2-stage
D1	44		62		80		108		140	
D2	M4X9		M5X10		M6X12		M8X15		M10X18	
D3	h6	12	h6	16	h6	22	h6	32	h6	40
D4	h6	35	h6	52	h6	68	h6	90	h6	120
D5		17		22		30		40		55
D6	M4X0.7P		M5X0.8P		M8X1.25P		M12X1.75P		M16X2P	
D8	50		70		90		120		155	
L2	24.5		36		46		70		97	
L3	4		4.5		6		7		9.5	
L4	2.5		3.5		4		5		5.5	
L5	14		25		32		50		70	
L6	2		2		2		4		6	
L9	4.5		4.8		7.2		10		12	
L10	10		12.5		19		28		36	
B1	h9	4	h9	5	h9	6	h9	10	h9	12
H1		13.5		18		24.5		35		43

(1) Dimensions are related to motor interface. Please contact APEX for details.

PEIR Series Dimension

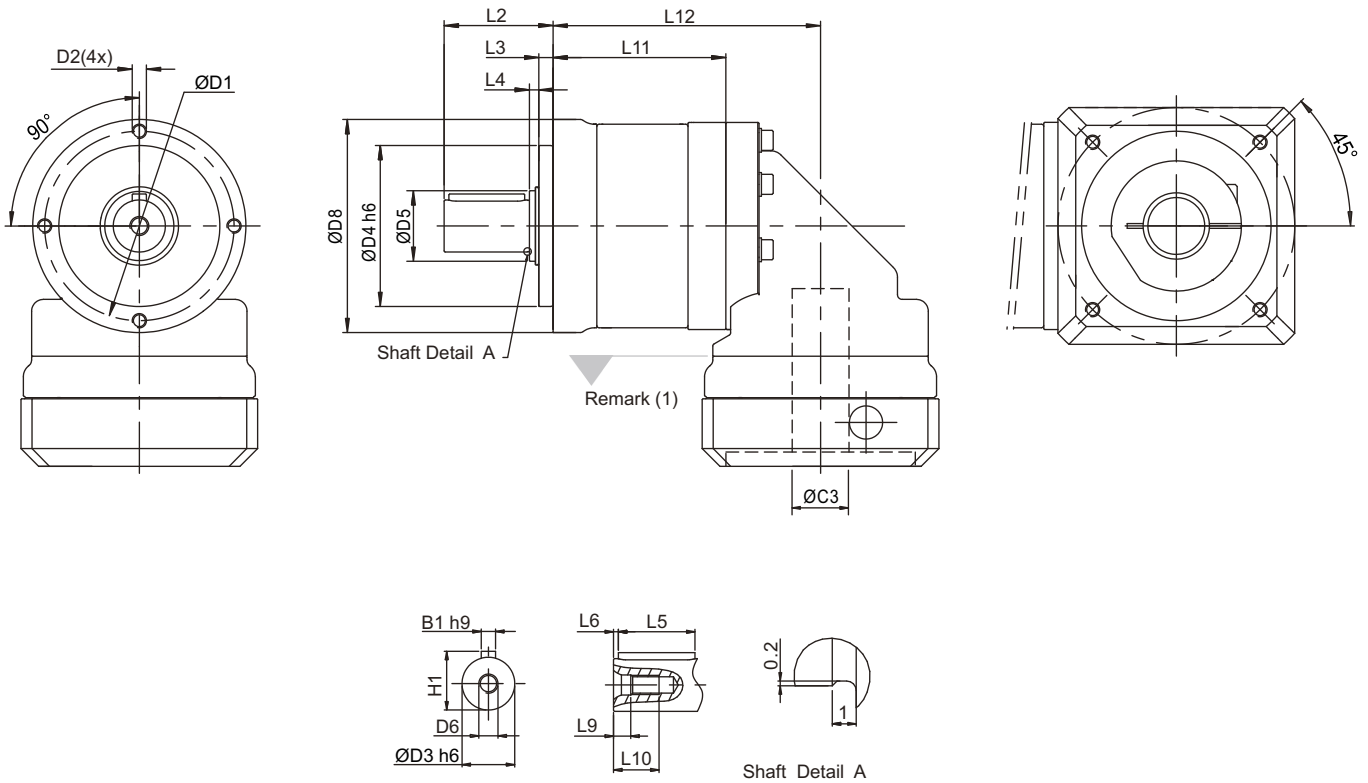

Dimension	PEIR 050		PEIR 070		PEIR 090		PEIR 120		PEIR 155	
	1-stage	2-stage	1-stage	2-stage	1-stage	2-stage	1-stage	2-stage	1-stage	2-stage
D1	44		62		80		108		140	
D2	M4X9		M5X10		M6X12		M8X15		M10X18	
D3 h6	12		16		22		32		40	
D4 h6	35		52		68		90		120	
D5	17		22		30		40		55	
D6	M4X0.7P		M5X0.8P		M8X1.25P		M12X1.75P		M16X2P	
D8	50		70		90		120		155	
L2	24.5		36		46		70		97	
L3	4		4.5		6		7		9.5	
L4	2.5		3.5		4		5		5.5	
L5	14		25		32		50		70	
L6	2		2		2		4		6	
L9	4.5		4.8		7.2		10		12	
L10	10		12.5		19		28		36	
L11	49.5	64.5	60	80	73	99.5	101	137	121	168.5
L12	74.5	89.5	89.5	109.5	113	139.5	152	188	178	225.5
B1 h9	4		5		6		10		12	
H1	13.5		18		24.5		35		43	

(1) Dimensions are related to motor interface. Please contact APEX for details.

PGII / PGIIR Gearbox Performance

Model No.		Stages ⁽⁶⁾	Ratio ⁽¹⁾	Type	PGII 040	PGII 060	PGII 080	PGII 120	PGII 160
					PGIIR 040	PGIIR 060	PGIIR 080	PGIIR 120	PGIIR 160
Nominal Output Torque T_{2N}	Nm	1	3	All	16	42	110	217	430
			4		16	42	113	223	440
			5		15	40	118	220	435
			7		12	35	96	198	366
			10		10	27	68	155	295
		2	15		15	40	109	213	424
			16		16	42	116	228	452
			20		16	42	116	230	454
			25		15	40	123	228	450
			30		15	40	108	212	422
			35		12	35	100	206	382
			40		16	43	117	232	459
			50		15	40	123	228	450
			70		12	35	100	206	382
			100		10	27	70	162	308
		3	120		19	50	137	-	-
			160		16	43	118	-	-
			200		16	43	118	-	-
			280		12	35	99	-	-
			350		12	35	99	-	-
500	15		40	122	-	-			
700	12		35	99	-	-			
1000	10	27	70	-	-				
Emergency Stop Torque T_{2NOT}	Nm	1,2,3	3~1000	All	3 times T_{2N}				
Max. Acceleration Torque T_{2B}	Nm	1,2,3	3~1000	All	$T_{2B} = 60\%$ of T_{2NOT}				
No Load Running Torque ⁽⁴⁾	Nm	1	3~10	PGII	0.05	0.10	0.40	0.80	2.50
				PGIIR	0.10	0.15	0.45	0.85	2.55
		2	15~100	PGII	0.05	0.10	0.30	0.40	0.80
				PGIIR	0.10	0.15	0.35	0.45	0.85
		3	120~1000	PGII	0.05	0.10	0.40	-	-
				PGIIR	0.10	0.15	0.45	-	-
Backlash ⁽²⁾	arcmin	1	3~10	PGII	≤ 8	≤ 7	≤ 6	≤ 6	≤ 6
				PGIIR	≤ 12	≤ 11	≤ 10	≤ 10	≤ 10
		2	15~100	PGII	≤ 10	≤ 9	≤ 8	≤ 8	≤ 8
				PGIIR	≤ 14	≤ 13	≤ 12	≤ 12	≤ 12
		3	120~1000	PGII	≤ 12	≤ 11	≤ 10	-	-
				PGIIR	≤ 16	≤ 15	≤ 14	-	-
Torsional Rigidity	Nm/arcmin	1,2,3	3~1000	All	0.5	2	8	12	16
Nominal Input Speed n_{1N}	rpm	1,2,3	3~1000	All	4,500	4,000	3,600	3,600	2,500
Max. Input Speed n_{1B}	rpm	1,2,3	3~1000	All	8,000	6,000	6,000	4,800	3,600
Max. Radial Load F_{2rB} ⁽³⁾	N	1,2,3	3~1000	All	520	1,030	1,570	3,590	4,690
Max. Axial Load F_{2aB} ⁽³⁾	N	1,2,3	3~1000	All	260	515	785	1,795	2,345
Operating Temp	°C	1,2,3	3~1000	All	0° C ~ +90° C				
Degree of Gearbox Protection		1,2,3	3~1000	All	IP65				
Lubrication		1,2,3	3~1000	All	Synthetic lubrication grease				
Mounting Position		1,2,3	3~1000	All	All directions				
Running Noise ⁽⁴⁾	dB(A)	1,2,3	3~1000	PGII	≤ 60	≤ 62	≤ 64	≤ 66	≤ 68
				PGIIR	≤ 70	≤ 72	≤ 74	≤ 75	≤ 77
Max. bending moment based on the gearbox input flange M_b ⁽⁵⁾	Nm	1,2,3	3~1000	PGII	5	12	22	45	54
				PGIIR	3	6	10	17	19
Efficiency η	%	1	3~10	PGII	≥ 97%				
				PGIIR	≥ 93%				
		2	15~100	PGII	≥ 94%				
				PGIIR	≥ 90%				
		3	120~1000	PGII	≥ 91%				
				PGIIR	≥ 87%				

(1) Ratio ($i = N_{in} / N_{out}$).(2) Backlash is measured at 2% of Nominal Output Torque T_{2N} .

(3) Applied to the output shaft center at 100 rpm.

(4) The dB values are measured by gearbox with ratio 10 (1-stage) or ratio 100 (2-stage), or ratio 1,000 (3-stage) no loading at 3,000 RPM or at the respective Nominal Input Speed by bigger model size.

By lower ratio and/or higher RPM, the noise level could be 3 to 5 dB higher.

(5) Max. motor weight* (kg) = $\frac{0.1 \times Mb}{\text{motor length (m)}}$

*with symmetrically distributed motor weight

*with horizontal and stationary mounting

(6) 5 years warranty.

PGII Gearbox Inertia

Model No.	PGII 040			PGII 060			PGII 080			PGII 120		PGII 160	
$\varnothing^{(A)}$ (C3)	1-st.	2-st.	3-st.	1-st.	2-st.	3-st.	1-st.	2-st.	3-st.	1-st.	2-st.	1-st.	2-st.
8	0.10	0.10	0.10	0.12	0.10	0.10	-	-	-	-	-	-	-
11	0.16	0.16	0.16	0.19	0.16	0.16	-	-	-	-	-	-	-
14	-	-	-	0.22	0.20	0.20	0.36	0.24	0.20	-	-	-	-
19	-	-	-	1.53	1.51	1.51	1.70	1.58	1.54	2.20	1.73	-	2.18
24	-	-	-	-	-	-	2.24	2.12	2.09	2.74	2.27	4.52	2.73
28	-	-	-	-	-	-	2.68	2.55	2.52	3.17	2.70	4.94	3.15
32	-	-	-	-	-	-	-	-	-	7.77	7.30	9.70	7.91
35	-	-	-	-	-	-	-	-	-	10.80	10.30	12.80	11.00
38	-	-	-	-	-	-	-	-	-	14.00	13.50	16.00	14.20
42	-	-	-	-	-	-	-	-	-	-	-	24.50	-

PGIIR Gearbox Inertia

Model No.	PGIIR 040			PGIIR 060			PGIIR 080			PGIIR 120		PGIIR 160	
$\varnothing^{(A)}$ (C3)	1-st.	2-st.	3-st.	1-st.	2-st.	3-st.	1-st.	2-st.	3-st.	1-st.	2-st.	1-st.	2-st.
8	0.18	0.18	0.18	0.36	0.36	0.36	-	-	-	-	-	-	-
11	0.20	0.20	0.20	0.39	0.39	0.39	-	-	-	-	-	-	-
14	-	-	-	0.43	0.43	0.43	1.87	1.87	1.87	-	-	-	-
19	-	-	-	1.24	1.24	1.24	2.67	2.67	2.67	6.80	6.80	-	13.57
24	-	-	-	-	-	-	2.97	2.97	2.97	7.10	7.10	13.87	13.87
28	-	-	-	-	-	-	3.47	3.47	3.47	7.59	7.59	14.36	14.36
32	-	-	-	-	-	-	-	-	-	10.56	10.56	17.33	17.33
35	-	-	-	-	-	-	-	-	-	11.97	11.97	18.74	18.74
38	-	-	-	-	-	-	-	-	-	13.95	13.95	20.79	20.79
42	-	-	-	-	-	-	-	-	-	-	-	26.54	-

Permitted Radial And Axial Loads^(B)

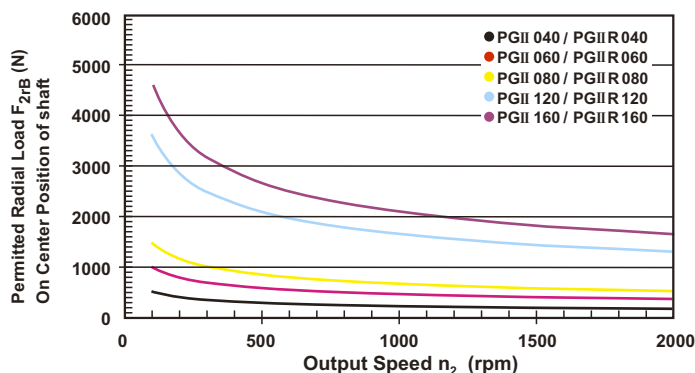
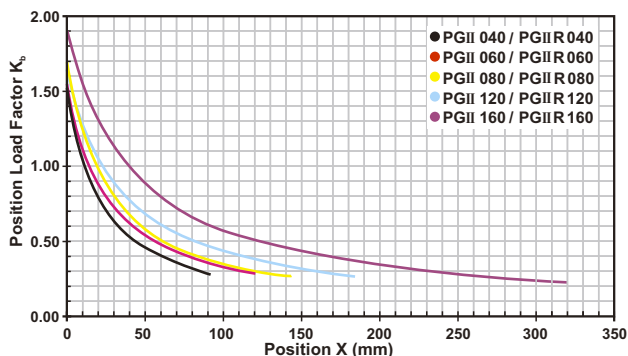

If radial force F_{2r} is not exerted on the center of the output shaft $X < 1/2 L$ or $X > 1/2 L$, the permitted radial and axial loads can be calculated by the position load factor K_s on the above diagram.

Permitted radial load F_{2r} on center of output shaft $X = 1/2 L$ for various output speeds.

(A) \varnothing = Input shaft diameter.

(B) Permitted loading values on the output shaft. Please refer to P. 33 glossary.

PGII Series Dimension

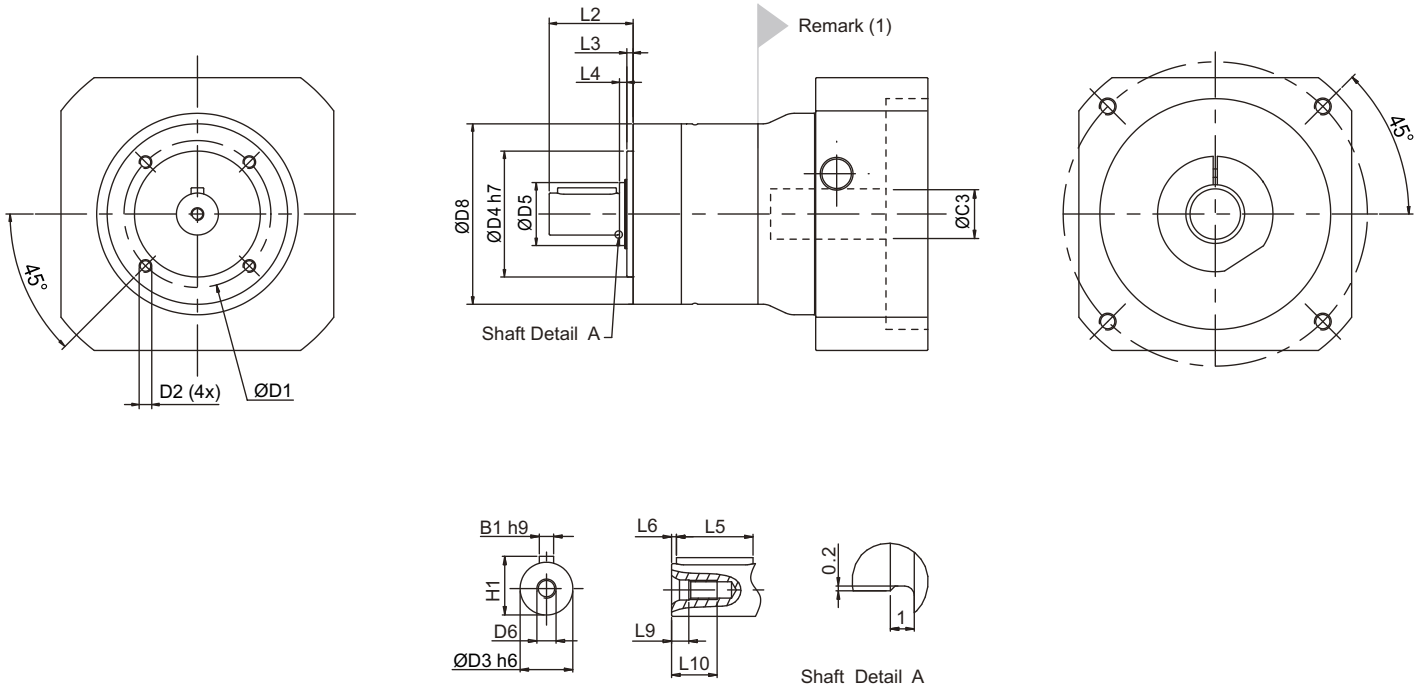

Dimension	PGII 040			PGII 060			PGII 080			PGII 120			PGII 160		
	1-st.	2-st.	3-st.	1-st.	2-st.	3-st.	1-st.	2-st.	3-st.	1-st.	2-st.	-	1-st.	2-st.	-
D1	34			52			70			100			145		
D2	M4X9			M5X10			M6X12			M10X18			M12X22		
D3	h6	10		14		20		25		40		130		55	
D4	h7	26		40		60		80		100		130		160	
D5	17			17			30			40			55		
D6	M3X0.5P			M5X0.8P			M6X1P			M10X1.5P			M16X2P		
D8	44			60			86			114			160		
L2	26			35			40			55			87		
L3	2			3			3			4			5		
L4	1			2			3.5			5			5.5		
L5	18			25			28			40			65		
L6	2.5			2.5			4			5			8		
L9	2.6			4.8			5			7.5			12		
L10	9			12.5			16.5			22			36		
B1	h9	3		5		6		8		12		12		43	
H1	11.2			16			22.5			28			43		

(1) Dimensions are related to motor interface. Please contact APEX for details.

PGII R Series Dimension

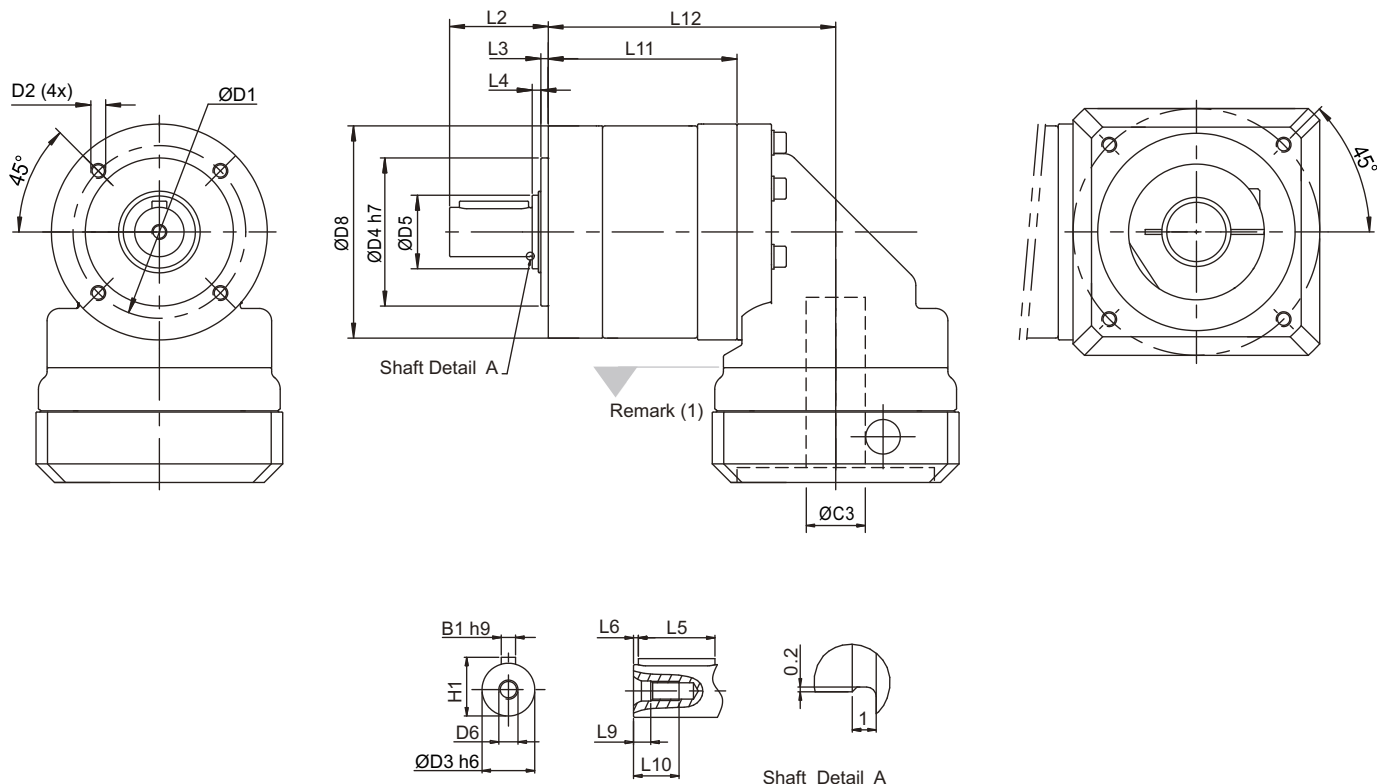

Dimension	PGII R 040			PGII R 060			PGII R 080			PGII R 120			PGII R 160		
	1-st.	2-st.	3-st.	1-st.	2-st.	3-st.	1-st.	2-st.	3-st.	1-st.	2-st.	-	1-st.	2-st.	-
D1	34			52			70			100			145		
D2	M4X9			M5X10			M6X12			M10X18			M12X22		
D3	h6	10		14		20		25		40		130			
D4	h7	26		40		60		80		100		130			
D5	17			17			30			40			55		
D6	M3X0.5P			M5X0.8P			M6X1P			M10X1.5P			M16X2P		
D8	44			60			86			114			160		
L2	26			35			40			55			87		
L3	2			3			3			4			5		
L4	1			2			3.5			5			5.5		
L5	18			25			28			40			65		
L6	2.5			2.5			4			5			8		
L9	2.6			4.8			5			7.5			12		
L10	9			12.5			16.5			22			36		
L11	53	68	82	66.5	86.5	105.5	76.5	103	128.5	104	140	-	125.5	173	-
L12	78	93	107	96	116	135	116.5	143	168.5	155	191	-	182.5	230	-
B1	h9	3		5		6		8		12		43			
H1	11.2			16			22.5			28			43		

(1) Dimensions are related to motor interface. Please contact APEX for details.

PA II / PA IIR Gearbox Performance

Model No.	Stages	Ratio ⁽¹⁾	Type	PAII 042	PAII 060	PAII 090	PAII 115	PAII 142	
				PAIIR 042	PAIIR 060	PAIIR 090	PAIIR 115	PAIIR 142	
Nominal Output Torque T _{2N}	1	3	AII	16	42	110	217	430	
		4		16	42	113	223	440	
		5		15	40	118	220	435	
		7		12	35	96	198	366	
		9		8	24	60	125	273	
		10		10	27	68	155	295	
	2	15		15	40	109	213	424	
		16		16	42	116	228	452	
		20		16	42	116	230	454	
		25		15	40	123	228	450	
		30		15	40	108	212	422	
		35		12	35	100	206	382	
		40		16	43	117	232	459	
		50		15	40	123	228	450	
		70		12	35	100	206	382	
		81		8	24	59	131	285	
		100		10	27	70	162	308	
		Emergency Stop Torque T _{2NOT}		Nm	1,2	3~100	AII 3 times T _{2N}		
Max. Acceleration Torque T _{2B}	Nm	1,2	3~100	AII T _{2B} = 60% of T _{2NOT}					
No Load Running Torque ⁽⁴⁾	1	3~10	PAII	0.05	0.10	0.40	0.80	2.50	
			PAIIR	0.10	0.15	0.45	0.85	2.55	
	2	15~100	PAII	0.05	0.10	0.30	0.40	0.80	
			PAIIR	0.10	0.15	0.35	0.45	0.85	
Backlash ⁽²⁾	1	3~10	PAII	≤ 8	≤ 7	≤ 6	≤ 6	≤ 6	
			PAIIR	≤ 12	≤ 11	≤ 10	≤ 10	≤ 10	
	2	15~100	PAII	≤ 10	≤ 9	≤ 8	≤ 8	≤ 8	
			PAIIR	≤ 14	≤ 13	≤ 12	≤ 12	≤ 12	
Torsional Rigidity	Nm/arcmin	1,2	3~100	AII	0.9	2.2	8	12	16
Nominal Input Speed n _{1N}	rpm	1,2	3~100	AII	4,500	4,000	3,600	3,600	2,500
Max. Input Speed n _{1B}	rpm	1,2	3~100	AII	8,000	6,000	6,000	4,800	3,600
Max. Radial Load F _{2rB} ⁽³⁾	N	1,2	3~100	AII	810	1,150	1,530	3,470	4,640
Max. Axial Load F _{2aB} ⁽³⁾	N	1,2	3~100	AII	405	575	765	1,735	2,320
Operating Temp	°C	1,2	3~100	AII	0° C ~ +90° C				
Degree of Gearbox Protection		1,2	3~100	AII	IP65				
Lubrication		1,2	3~100	AII	Synthetic lubrication grease				
Mounting Position		1,2	3~100	AII	All directions				
Running Noise ⁽⁴⁾	dB(A)	1,2	3~100	PAII	≤ 60	≤ 62	≤ 64	≤ 66	≤ 68
				PAIIR	≤ 70	≤ 72	≤ 74	≤ 75	≤ 77
Max. bending moment based on the gearbox input flange Mb ⁽⁵⁾	Nm	1,2	3~100	PAII	5	12	22	45	54
				PAIIR	3	6	10	17	19
Efficiency η	%	1	3~10	PAII	≥ 97%				
				PAIIR	≥ 93%				
		2	15~100	PAII	≥ 94%				
				PAIIR	≥ 90%				

(1) Ratio ($i = N_{in} / N_{out}$).

(2) Backlash is measured at 2% of Nominal Output Torque T_{2N}.

(3) Applied to the output shaft center at 100 rpm.

(4) The dB values are measured by gearbox with ratio 10 (1-stage) or ratio 100 (2-stage), no loading at 3,000 RPM or at the respective Nominal Input Speed by bigger model size.

By lower ratio and/or higher RPM, the noise level could be 3 to 5 dB higher.

(5) Max. motor weight* (kg) = $\frac{0.1 \times Mb}{\text{motor length (m)}}$

*with symmetrically distributed motor weight

*with horizontal and stationary mounting

(6) 5 years warranty.

PA II Gearbox Inertia

Model No.		PAII 042		PAII 060		PAII 090		PAII 115		PAII 142	
$\varnothing^{(A)}$ (C3)		1-stage	2-stage	1-stage	2-stage	1-stage	2-stage	1-stage	2-stage	1-stage	2-stage
8	kg.cm ²	0.10	0.10	0.12	0.10	-	-	-	-	-	-
11		0.16	0.16	0.19	0.16	-	-	-	-	-	-
14		-	-	0.22	0.20	0.36	0.24	-	-	-	-
19		-	-	1.53	1.51	1.70	1.58	2.20	1.73	-	2.18
24		-	-	-	-	2.24	2.12	2.74	2.27	4.52	2.73
28		-	-	-	-	2.68	2.55	3.17	2.70	4.94	3.15
32		-	-	-	-	-	-	7.77	7.30	9.70	7.91
35		-	-	-	-	-	-	10.80	10.30	12.80	11.00
38		-	-	-	-	-	-	14.00	13.50	16.00	14.20
42		-	-	-	-	-	-	-	-	24.50	-

PAII R Gearbox Inertia

Model No.		PAII R 042		PAII R 060		PAII R 090		PAII R 115		PAII R 142	
$\varnothing^{(A)}$ (C3)		1-stage	2-stage	1-stage	2-stage	1-stage	2-stage	1-stage	2-stage	1-stage	2-stage
8	kg.cm ²	0.18	0.18	0.36	0.36	-	-	-	-	-	-
11		0.20	0.20	0.39	0.39	-	-	-	-	-	-
14		-	-	0.43	0.43	1.87	1.87	-	-	-	-
19		-	-	1.24	1.24	2.67	2.67	6.80	6.80	-	13.57
24		-	-	-	-	2.97	2.97	7.10	7.10	13.87	13.87
28		-	-	-	-	3.47	3.47	7.59	7.59	14.36	14.36
32		-	-	-	-	-	-	10.56	10.56	17.33	17.33
35		-	-	-	-	-	-	11.97	11.97	18.74	18.74
38		-	-	-	-	-	-	13.95	13.95	20.79	20.79
42		-	-	-	-	-	-	-	-	26.54	-

Permitted Radial And Axial Loads^(B)

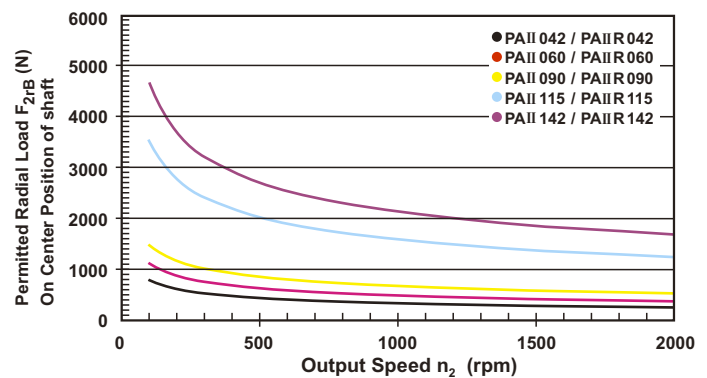
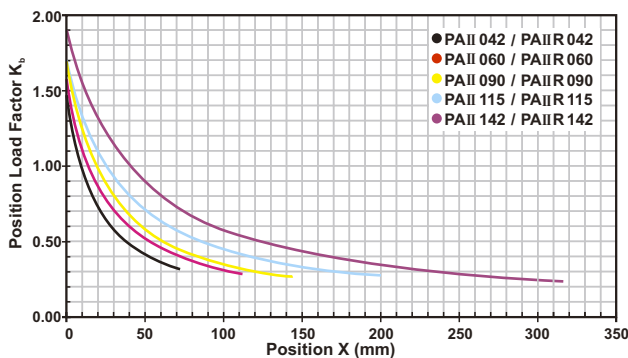

If radial force F_{zr} is not exerted on the center of the output shaft $X < 1/2 L$ or $X > 1/2 L$, the permitted radial and axial loads can be calculated by the position load factor K_s on the above diagram.

Permitted radial load F_{zr} on center of output shaft $X = 1/2 L$ for various output speeds.

(A) \varnothing = Input shaft diameter.

(B) Permitted loading values on the output shaft. Please refer to P. 33 glossary.

PA II Series Dimension

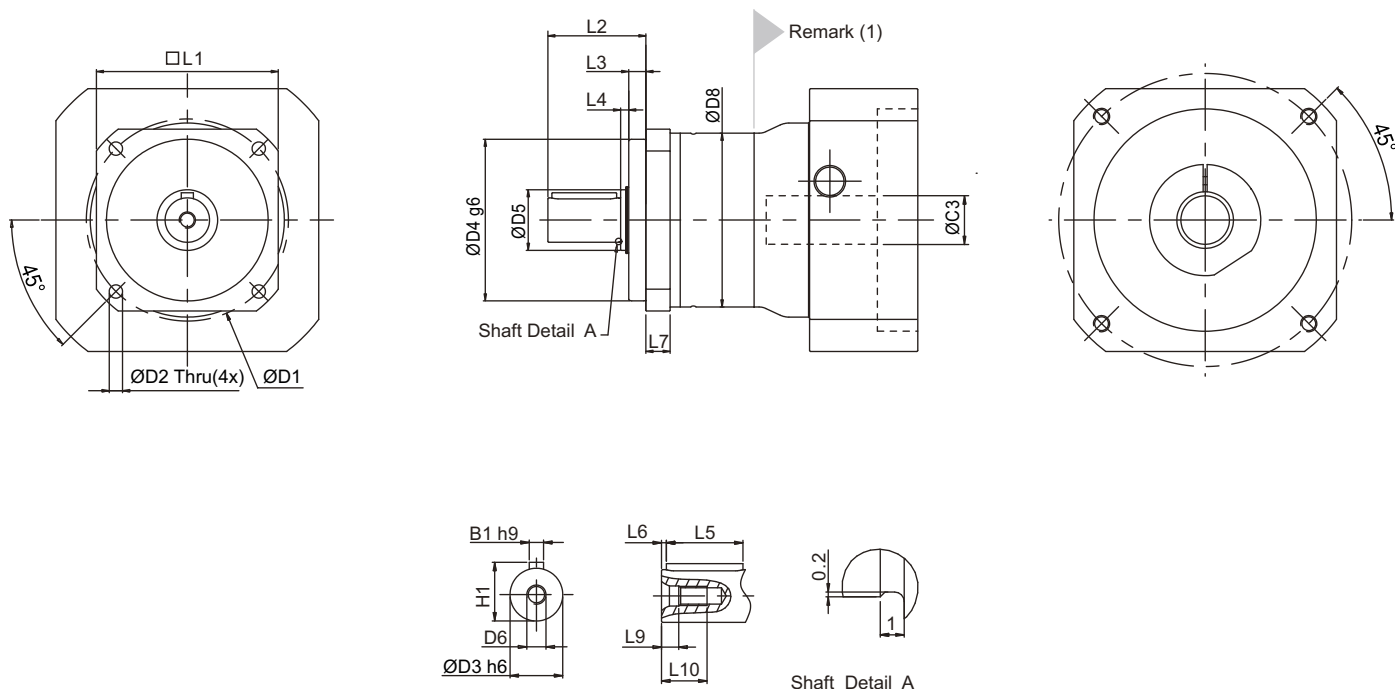

Dimension	PAII 042		PAII 060		PAII 090		PAII 115		PAII 142	
	1-stage	2-stage	1-stage	2-stage	1-stage	2-stage	1-stage	2-stage	1-stage	2-stage
D1	50		70		100		130		165	
D2	3.4		5.5		6.6		9		11	
D3	h6	13	16		22		32		40	
D4	g6	35	50		80		110		130	
D5		17	22		30		40		55	
D6		M4X0.7P	M5X0.8P		M8X1.25P		M12X1.75P		M16X2P	
D8		44	60		86		114		140	
L1		42	60		90		115		142	
L2		26	37		48.5		65		97	
L3		5.5	5.5		8.5		10		12.5	
L4		2.5	3.5		4		5		5.5	
L5		14	25		32		40		63	
L6		2	2		2		5		5	
L7		6.5	10		12		16		20	
L9		4.5	4.8		7.2		10		12	
L10		10	12.5		19		28		36	
B1	h9	5	5		6		10		12	
H1		15	18		24.5		35		43	

(1) Dimensions are related to motor interface. Please contact APEX for details.

PA IIR Series Dimension

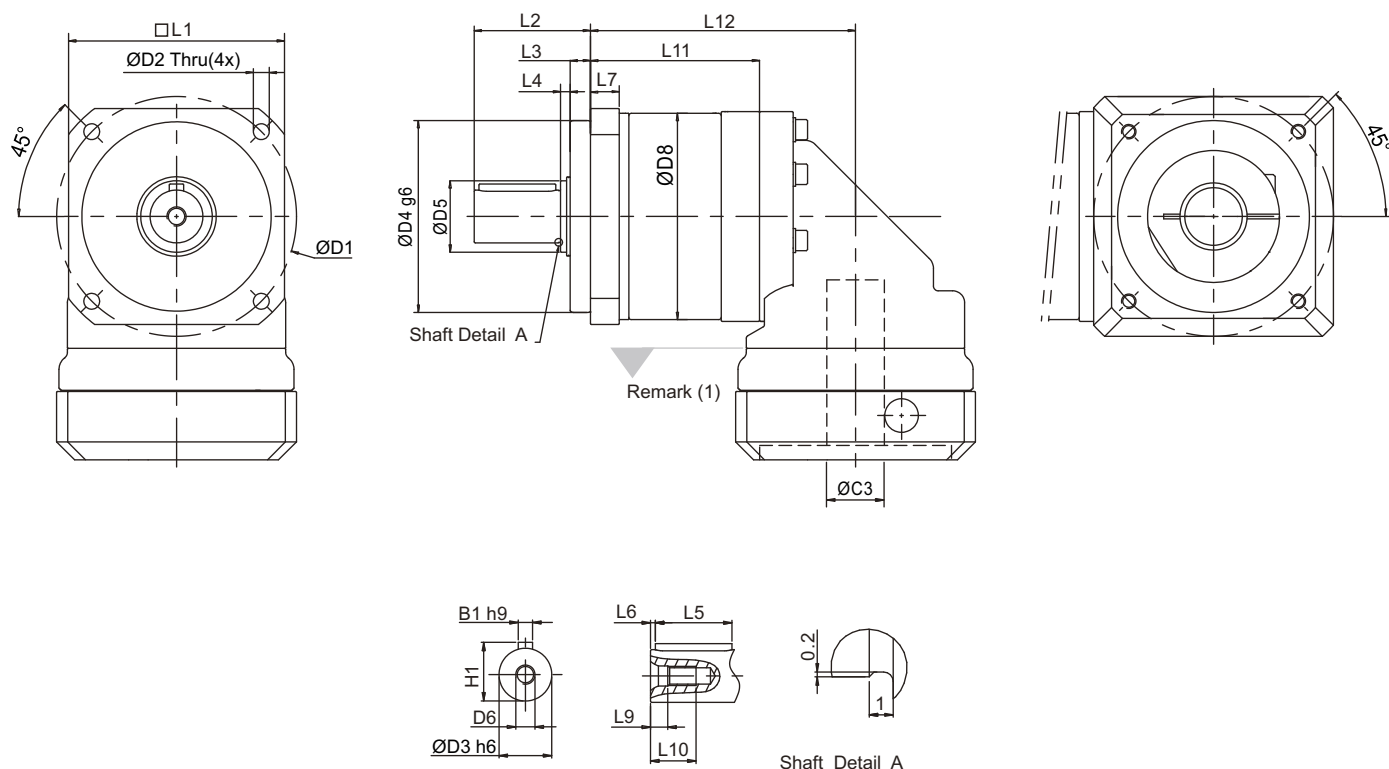

Dimension	PAIIR 042		PAIIR 060		PAIIR 090		PAIIR 115		PAIIR 142	
	1-stage	2-stage	1-stage	2-stage	1-stage	2-stage	1-stage	2-stage	1-stage	2-stage
D1	50		70		100		130		165	
D2	3.4		5.5		6.6		9		11	
D3 h6	13		16		22		32		40	
D4 g6	35		50		80		110		130	
D5	17		22		30		40		55	
D6	M4X0.7P		M5X0.8P		M8X1.25P		M12X1.75P		M16X2P	
D8	44		60		86		114		140	
L1	42		60		90		115		142	
L2	26		37		48.5		65		97	
L3	5.5		5.5		8.5		10		12.5	
L4	2.5		3.5		4		5		5.5	
L5	14		25		32		40		63	
L6	2		2		2		5		5	
L7	6.5		10		12		16		20	
L9	4.5		4.8		7.2		10		12	
L10	10		12.5		19		28		36	
L11	48	63	59	79	70.5	97	98	134	118	165.5
L12	73	88	88.5	108.5	110.5	137	149	185	175	222.5
B1 h9	5		5		6		10		12	
H1	15		18		24.5		35		43	

(1) Dimensions are related to motor interface. Please contact APEX for details.

PSII / PSIIIR Gearbox Performance

Model No.	Stages	Ratio ⁽¹⁾	Type	PSII A	PSII B	PSII C	PSII D	PSII E	
				PSIIIR A	PSIIIR B	PSIIIR C	PSIIIR D	PSIIIR E	
Nominal Output Torque T_{2N}	1	3	All	16	42	110	217	430	
		4		16	42	113	223	440	
		5		15	40	118	220	435	
		7		12	35	96	198	366	
		9		8	24	60	125	273	
		10		10	27	68	155	295	
	2	15		15	40	109	213	424	
		16		16	42	116	228	452	
		20		16	42	116	230	454	
		25		15	40	123	228	450	
		30		15	40	108	212	422	
		35		12	35	100	206	382	
		40		16	43	117	232	459	
		50		15	40	123	228	450	
		70		12	35	100	206	382	
		81		8	24	59	131	285	
		100		10	27	70	162	308	
		Emergency Stop Torque T_{2NOT}		Nm	1,2	3~100	All	3 times T_{2N}	
Max. Acceleration Torque T_{2B}	Nm	1,2	3~100	All	$T_{2B} = 60\%$ of T_{2NOT}				
No Load Running Torque ⁽⁴⁾	1	3~10	PSII	0.05	0.10	0.40	0.80	2.50	
			PSIIIR	0.10	0.15	0.45	0.85	2.55	
	2	15~100	PSII	0.05	0.10	0.30	0.40	0.80	
			PSIIIR	0.10	0.15	0.35	0.45	0.85	
Backlash ⁽²⁾	1	3~10	PSII	≤ 8	≤ 7	≤ 6	≤ 6	≤ 6	
			PSIIIR	≤ 12	≤ 11	≤ 10	≤ 10	≤ 10	
	2	15~100	PSII	≤ 10	≤ 9	≤ 8	≤ 8	≤ 8	
			PSIIIR	≤ 14	≤ 13	≤ 12	≤ 12	≤ 12	
Torsional Rigidity	Nm/arcmin	1,2	3~100	All	0.6	1.5	6	10.5	18
Nominal Input Speed n_{1N}	rpm	1,2	3~100	All	4,500	4,000	3,600	3,600	2,500
Max. Input Speed n_{1B}	rpm	1,2	3~100	All	8,000	6,000	6,000	4,800	3,600
Max. Radial Load F_{2rB} ⁽³⁾	N	1,2	3~100	All	840	1,290	1,510	3,780	5,420
Max. Axial Load F_{2aB} ⁽³⁾	N	1,2	3~100	All	420	645	755	1,890	2,710
Operating Temp	°C	1,2	3~100	All	0° C ~ +90° C				
Degree of Gearbox Protection		1,2	3~100	All	IP65				
Lubrication		1,2	3~100	All	Synthetic lubrication grease				
Mounting Position		1,2	3~100	All	All directions				
Running Noise ⁽⁴⁾	dB(A)	1,2	3~100	PSII	≤ 60	≤ 62	≤ 64	≤ 66	≤ 68
				PSIIIR	≤ 70	≤ 72	≤ 74	≤ 75	≤ 77
Max. bending moment based on the gearbox input flange M_b ⁽⁵⁾	Nm	1,2	3~100	PSII	5	12	22	45	54
				PSIIIR	3	6	10	17	19
Efficiency η	%	1	3~10	PSII	$\geq 97\%$				
				PSIIIR	$\geq 93\%$				
		2	15~100	PSII	$\geq 94\%$				
				PSIIIR	$\geq 90\%$				

(1) Ratio ($i = N_{in} / N_{out}$).(2) Backlash is measured at 2% of Nominal Output Torque T_{2N} .

(3) Applied to the output shaft center at 100 rpm.

(4) The dB values are measured by gearbox with ratio 10 (1-stage) or ratio 100 (2-stage), no loading at 3,000 RPM or at the respective Nominal Input Speed by bigger model size.

By lower ratio and/or higher RPM, the noise level could be 3 to 5 dB higher.

(5) Max. motor weight* (kg) = $\frac{0.1 \times Mb}{\text{motor length (m)}}$

*with symmetrically distributed motor weight

*with horizontal and stationary mounting

(6) 5 years warranty.

PSII Gearbox Inertia

Model No.	PSII A		PSII B		PSII C		PSII D		PSII E	
$\varnothing^{(A)}$ (C3)	1-stage	2-stage	1-stage	2-stage	1-stage	2-stage	1-stage	2-stage	1-stage	2-stage
8	0.10	0.10	0.12	0.10	-	-	-	-	-	-
11	0.16	0.16	0.19	0.16	-	-	-	-	-	-
14	-	-	0.22	0.20	0.36	0.24	-	-	-	-
19	-	-	1.53	1.51	1.70	1.58	2.20	1.73	-	2.18
24	-	-	-	-	2.24	2.12	2.74	2.27	4.52	2.73
28	-	-	-	-	2.68	2.55	3.17	2.70	4.94	3.15
32	-	-	-	-	-	-	7.77	7.30	9.70	7.91
35	-	-	-	-	-	-	10.80	10.30	12.80	11.00
38	-	-	-	-	-	-	14.00	13.50	16.00	14.20
42	-	-	-	-	-	-	-	-	24.50	-

PSIIR Gearbox Inertia

Model No.	PSIIR A		PSIIR B		PSIIR C		PSIIR D		PSIIR E	
$\varnothing^{(A)}$ (C3)	1-stage	2-stage	1-stage	2-stage	1-stage	2-stage	1-stage	2-stage	1-stage	2-stage
8	0.18	0.18	0.36	0.36	-	-	-	-	-	-
11	0.20	0.20	0.39	0.39	-	-	-	-	-	-
14	-	-	0.43	0.43	1.87	1.87	-	-	-	-
19	-	-	1.24	1.24	2.67	2.67	6.80	6.80	-	13.57
24	-	-	-	-	2.97	2.97	7.10	7.10	13.87	13.87
28	-	-	-	-	3.47	3.47	7.59	7.59	14.36	14.36
32	-	-	-	-	-	-	10.56	10.56	17.33	17.33
35	-	-	-	-	-	-	11.97	11.97	18.74	18.74
38	-	-	-	-	-	-	13.95	13.95	20.79	20.79
42	-	-	-	-	-	-	-	-	26.54	-

Permitted Radial And Axial Loads^(B)

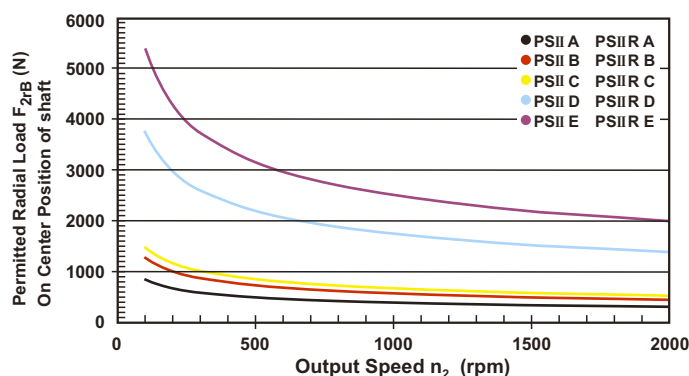
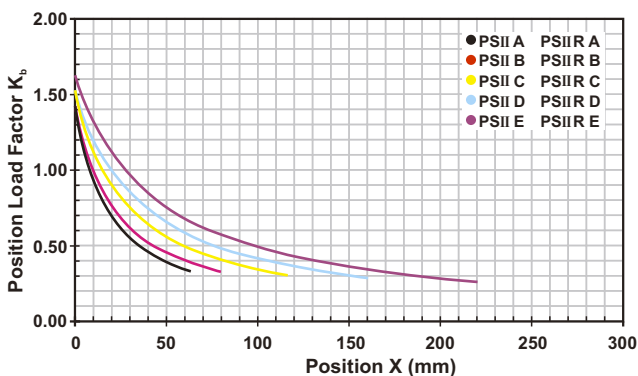

If radial force F_{2r} is not exerted on the center of the output shaft $X < 1/2 L$ or $X > 1/2 L$, the permitted radial and axial loads can be calculated by the position load factor K_s on the above diagram.

Permitted radial load F_{2r} on center of output shaft $X = 1/2 L$ for various output speeds.

(A) \varnothing = Input shaft diameter.

(B) Permitted loading values on the output shaft. Please refer to P. 33 glossary.

PSII Series Dimension

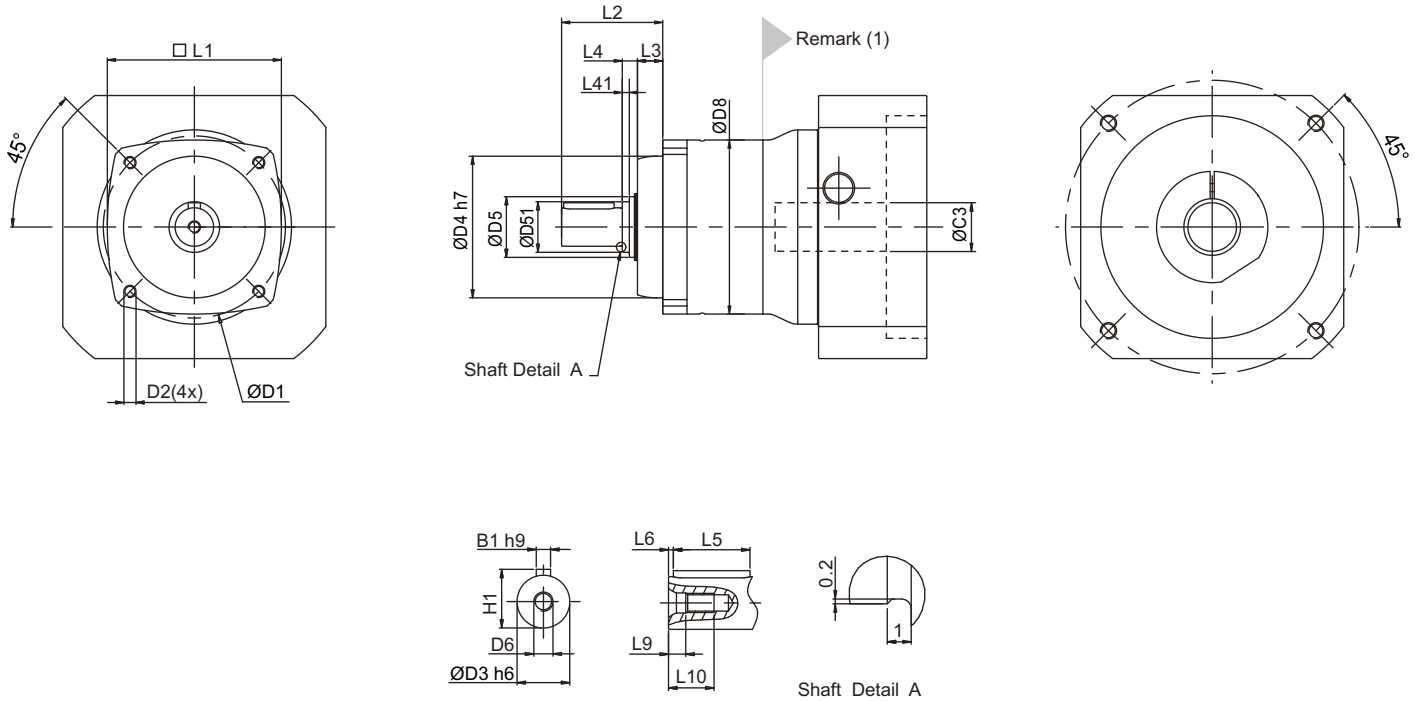

Dimension	PSII A		PSII B		PSII C		PSII D		PSII E	
	1-stage	2-stage	1-stage	2-stage	1-stage	2-stage	1-stage	2-stage	1-stage	2-stage
D1	47		60		90		115		135	
D2	M4X9		M5X10		M6X12		M8X18.5		M10X18	
D3	h6	10	12		19		24		32	
D4	h7	38	50		70		90		110	
D5		17	22		30		40		55	
D51		-	-		25		-		-	
D6	M3X0.5P		M4X0.7P		M6X1P		M8X1.25P		M12X1.75P	
D8		44	60		86		114		140	
L1		44	60		86		114		140	
L2		25	32		50		61		75	
L3		6.5	8.5		12.5		16		14.5	
L4		2.5	3.5		7.5		5		5.5	
L41		-	-		3.5		-		-	
L5		10	16		25		32		50	
L6		3	2		1		3		2	
L9		2.6	4.5		5		7.2		10	
L10		9	10		16.5		19		28	
B1	h9	3	4		6		8		10	
H1		11.2	13.5		21.5		27		35	

(1) Dimensions are related to motor interface. Please contact APEX for details.

PSIIR Series Dimension

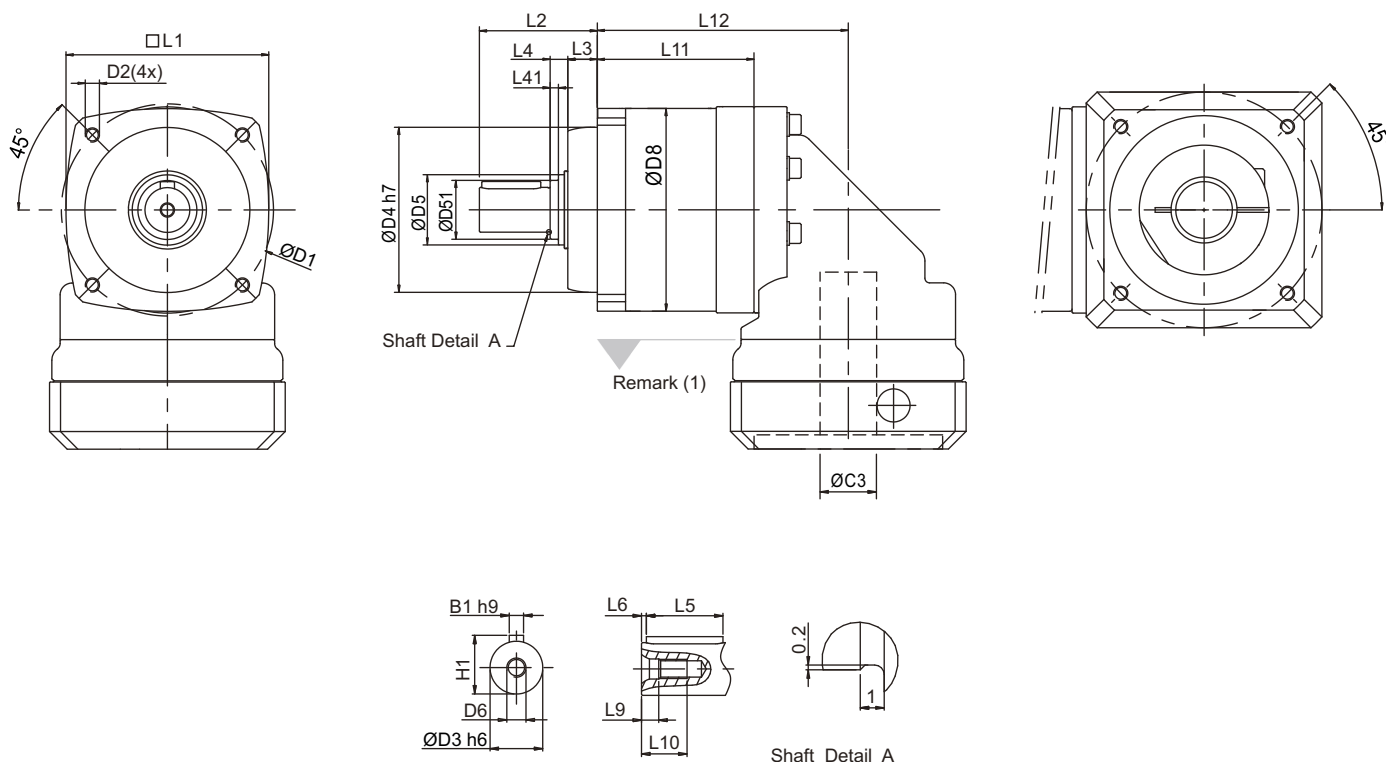

Dimension	PSIIR A		PSIIR B		PSIIR C		PSIIR D		PSIIR E	
	1-stage	2-stage	1-stage	2-stage	1-stage	2-stage	1-stage	2-stage	1-stage	2-stage
D1	47		60		90		115		135	
D2	M4X9		M5X10		M6X12		M8X18.5		M10X18	
D3	h6	10	12		19		24		32	
D4	h7	38	50		70		90		110	
D5	17		22		30		40		55	
D51	-		-		25		-		-	
D6	M3X0.5P		M4X0.7P		M6X1P		M8X1.25P		M12X1.75P	
D8	44		60		86		114		140	
L1	44		60		86		114		140	
L2	25		32		50		61		75	
L3	6.5		8.5		12.5		16		14.5	
L4	2.5		3.5		7.5		5		5.5	
L41	-		-		3.5		-		-	
L5	10		16		25		32		50	
L6	3		2		1		3		2	
L9	2.6		4.5		5		7.2		10	
L10	9		10		16.5		19		28	
L11	47	62	56	76	66.5	93	92	128	116	163.5
L12	72	87	85.5	105.5	106.5	133	143	179	173	220.5
B1	h9	3	4		6		8		10	
H1	11.2		13.5		21.5		27		35	

(1) Dimensions are related to motor interface. Please contact APEX for details.

PNII / PNIIR Gearbox Performance

Model No.	Stages	Ratio ⁽¹⁾	Type	PNII 017	PNII 023	PNII 034	PNII 042	PNII 056	
				PNIIR 017	PNIIR 023	PNIIR 034	PNIIR 042	PNIIR 056	
Nominal Output Torque T_{2N}	1	3	AII	16	42	110	217	430	
		4		16	42	113	223	440	
		5		15	40	118	220	435	
		7		12	35	96	198	366	
		10		10	27	68	155	295	
	2	15		15	40	109	213	424	
		16		16	42	116	228	452	
		20		16	42	116	230	454	
		25		15	40	123	228	450	
		30		15	40	108	212	422	
		35		12	35	100	206	382	
		40		16	43	117	232	459	
		50		15	40	123	228	450	
		70		12	35	100	206	382	
		100		10	27	70	162	308	
		Emergency Stop Torque T_{2NOT}		Nm	1,2	3~100	AII 3 times T_{2N}		
Max. Acceleration Torque T_{2B}	Nm	1,2	3~100	AII $T_{2B} = 60\%$ of T_{2NOT}					
No Load Running Torque ⁽⁴⁾	1	3~10	PNII	0.05	0.10	0.40	0.80	2.50	
			PNIIR	0.10	0.15	0.45	0.85	2.55	
	2	15~100	PNII	0.05	0.10	0.30	0.40	0.80	
			PNIIR	0.10	0.15	0.35	0.45	0.85	
Backlash ⁽²⁾	1	3~10	PNII	≤ 8	≤ 7	≤ 6	≤ 6	≤ 6	
			PNIIR	≤ 12	≤ 11	≤ 10	≤ 10	≤ 10	
	2	15~100	PNII	≤ 10	≤ 9	≤ 8	≤ 8	≤ 8	
			PNIIR	≤ 14	≤ 13	≤ 12	≤ 12	≤ 12	
Torsional Rigidity	Nm/arcmin	1,2	3~100	AII	0.90	1.50	6	12	14
Nominal Input Speed n_{1N}	rpm	1,2	3~100	AII	4,500	4,000	3,600	3,600	2,500
Max. Input Speed n_{1B}	rpm	1,2	3~100	AII	8,000	6,000	6,000	4,800	3,600
Max. Radial Load F_{2rB} ⁽³⁾	N	1,2	3~100	AII	480	1,100	1,580	3,500	5,420
Max. Axial Load F_{2aB} ⁽³⁾	N	1,2	3~100	AII	240	550	790	1,750	2,710
Operating Temp	°C	1,2	3~100	AII	0° C ~ +90° C				
Degree of Gearbox Protection		1,2	3~100	AII	IP65				
Lubrication		1,2	3~100	AII	Synthetic lubrication grease				
Mounting Position		1,2	3~100	AII	All directions				
Running Noise ⁽⁴⁾	dB(A)	1,2	3~100	PNII	≤ 60	≤ 62	≤ 64	≤ 66	≤ 68
				PNIIR	≤ 70	≤ 72	≤ 74	≤ 75	≤ 77
Max. bending moment based on the gearbox input flange M_b ⁽⁵⁾	Nm	1,2	3~100	PNII	5	12	22	45	54
				PNIIR	3	6	10	17	19
Efficiency η	%	1	3~10	PNII	$\geq 97\%$				
				PNIIR	$\geq 93\%$				
		2	15~100	PNII	$\geq 94\%$				
				PNIIR	$\geq 90\%$				

(1) Ratio ($i = N_{in} / N_{out}$).

(2) Backlash is measured at 2% of Nominal Output Torque T_{2N} .

(3) Applied to the output shaft center at 100 rpm.

(4) The dB values are measured by gearbox with ratio 10 (1-stage) or ratio 100 (2-stage), no loading at 3,000 RPM or at the respective Nominal Input Speed by bigger model size.

By lower ratio and/or higher RPM, the noise level could be 3 to 5 dB higher.

(5) Max. motor weight* (kg) = $\frac{0.1 \times M_b}{\text{motor length (m)}}$

*with symmetrically distributed motor weight

*with horizontal and stationary mounting

(6) 5 years warranty.

PNII Gearbox Inertia

Model No.	PNII 017		PNII 023		PNII 034		PNII 042		PNII 056	
$\varnothing^{(A)}$ (C3)	1-stage	2-stage	1-stage	2-stage	1-stage	2-stage	1-stage	2-stage	1-stage	2-stage
8	0.10	0.10	0.12	0.10	-	-	-	-	-	-
11	0.16	0.16	0.19	0.16	-	-	-	-	-	-
14	-	-	0.22	0.20	0.36	0.24	-	-	-	-
19	-	-	1.53	1.51	1.70	1.58	2.20	1.73	-	2.18
24	-	-	-	-	2.24	2.12	2.74	2.27	4.52	2.73
28	-	-	-	-	2.68	2.55	3.17	2.70	4.94	3.15
32	-	-	-	-	-	-	7.77	7.30	9.70	7.91
35	-	-	-	-	-	-	10.80	10.30	12.80	11.00
38	-	-	-	-	-	-	14.00	13.50	16.00	14.20
42	-	-	-	-	-	-	-	-	24.50	-

PNII R Gearbox Inertia

Model No.	PNII R 017		PNII R 023		PNII R 034		PNII R 042		PNII R 056	
$\varnothing^{(A)}$ (C3)	1-stage	2-stage	1-stage	2-stage	1-stage	2-stage	1-stage	2-stage	1-stage	2-stage
8	0.18	0.18	0.36	0.36	-	-	-	-	-	-
11	0.20	0.20	0.39	0.39	-	-	-	-	-	-
14	-	-	0.43	0.43	1.87	1.87	-	-	-	-
19	-	-	1.24	1.24	2.67	2.67	6.80	6.80	-	13.57
24	-	-	-	-	2.97	2.97	7.10	7.10	13.87	13.87
28	-	-	-	-	3.47	3.47	7.59	7.59	14.36	14.36
32	-	-	-	-	-	-	10.56	10.56	17.33	17.33
35	-	-	-	-	-	-	11.97	11.97	18.74	18.74
38	-	-	-	-	-	-	13.95	13.95	20.79	20.79
42	-	-	-	-	-	-	-	-	26.54	-

Permitted Radial And Axial Loads^(B)

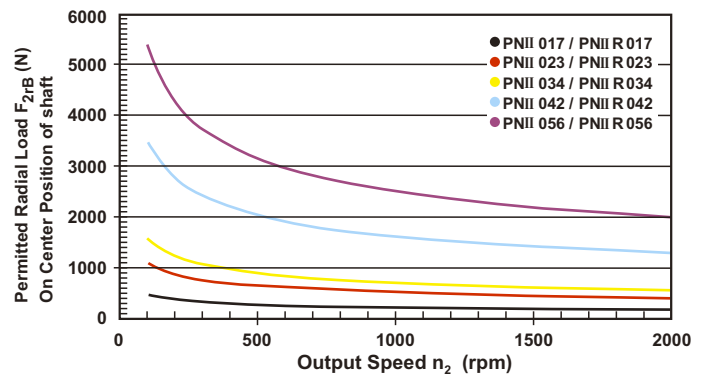
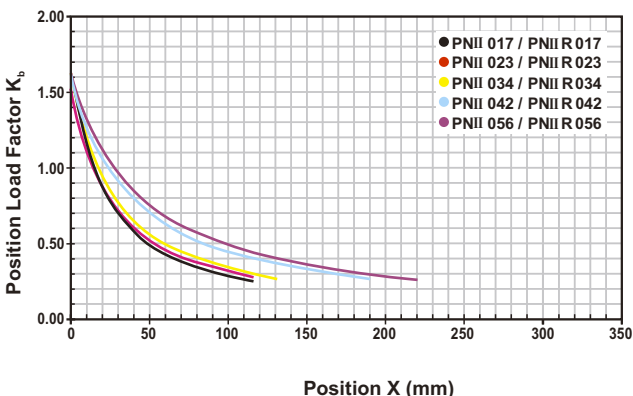

If radial force F_{2r} is not exerted on the center of the output shaft $X < 1/2xL$ or $X > 1/2xL$, the permitted radial and axial loads can be calculated by the position load factor K_b on the above diagram.

Permitted radial load F_{2r} on center of output shaft $X = 1/2 \times L$ for various output speeds.

(A) \varnothing = Input shaft diameter.

(B) Permitted loading values on the output shaft. Please refer to P. 33 glossary.

PNII Series Dimension

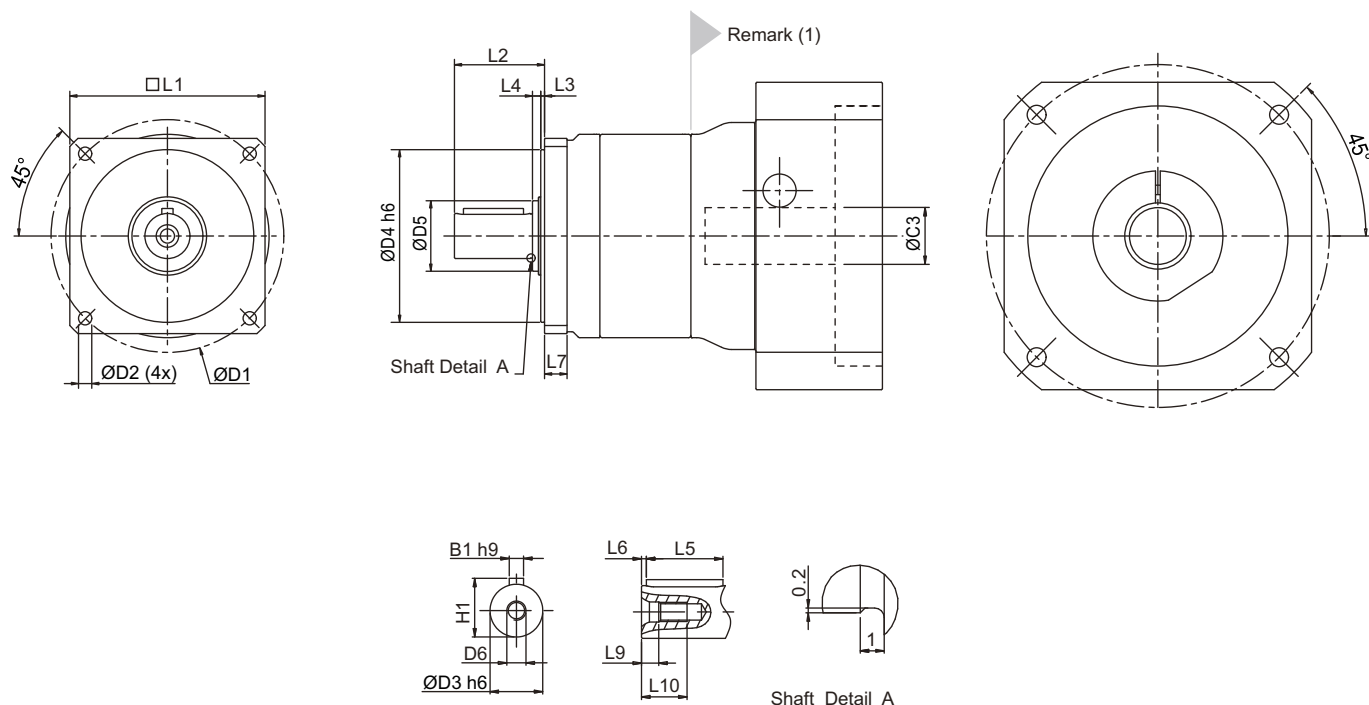

Remark (1)

Shaft Detail A

Shaft Detail A

Dimension	PNII 017		PNII 023		PNII 034		PNII 042		PNII 056	
	1-stage	2-stage	1-stage	2-stage	1-stage	2-stage	1-stage	2-stage	1-stage	2-stage
D1	43.815		66.675		98.425		125.73		177.8	
D2	3.4		5.2		5.6		7.2		10.5	
D3	h6		12.7		19.05		25.4		38.1	
D4	h6		22		73.025		55.55		114.3	
D5	17		17		30		35		55	
D6	M4X0.7P		M4X0.7P		M6X1P		M10X1.5P		M16X2P	
L1	41.91		57.15		82.55		106.68		146.05	
L2	31.75		31.75		38.1		50.8		63.5	
L3	1.6		1.6		1.6		1.6		3.2	
L4	1		1		3.5		1.5		5.5	
L5	19.05		19.05		25.4		31.75		38.1	
L6	3.788		3.788		3.807		5.175		8.563	
L7	6.35		9.525		9.525		12.7		19.05	
L9	4.5		4.5		5		7.5		12	
L10	10		10		16.5		22		36	
B1	h9		3.175		4.763		6.35		9.525	
H1	14.125		14.125		21.163		28.2		42.275	

(1) Dimensions are related to motor interface. Please contact APEX for details.

PNIR Series Dimension

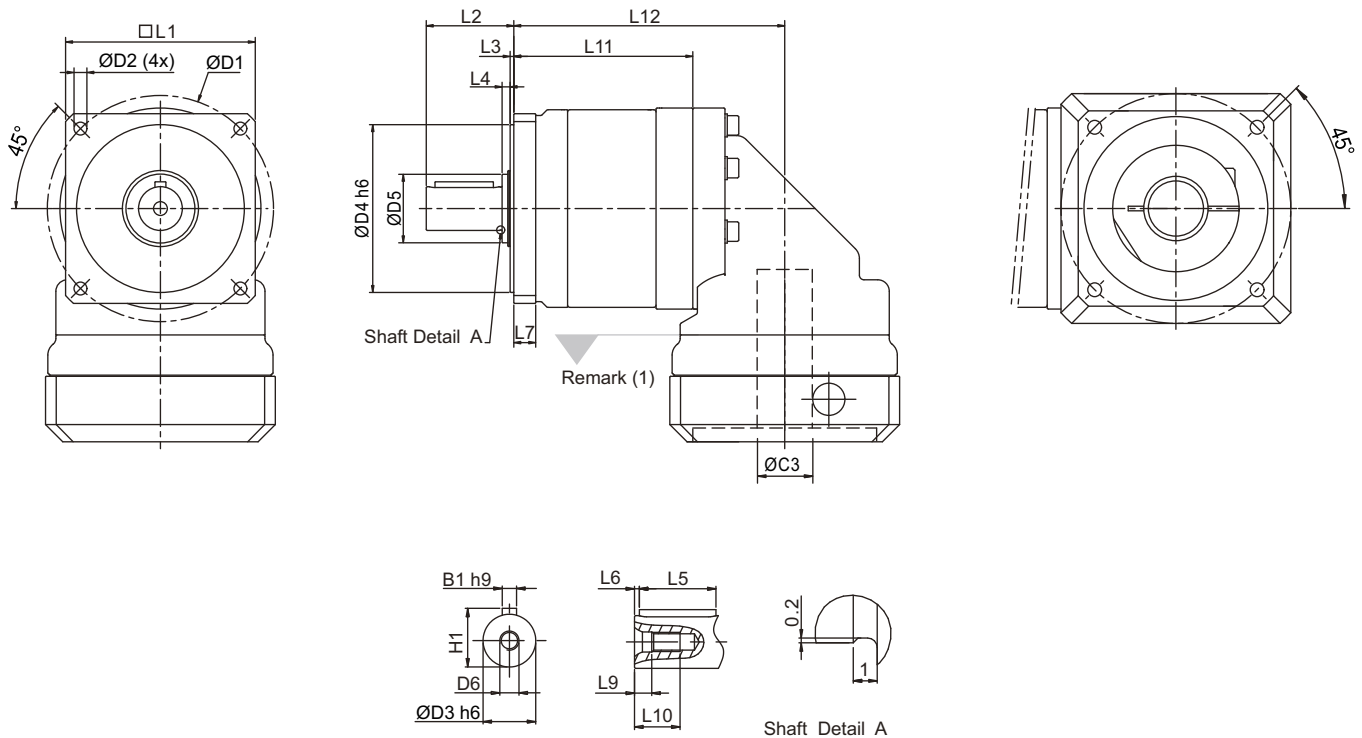

Dimension	PNIR 017		PNIR 023		PNIR 034		PNIR 042		PNIR 056	
	1-stage	2-stage	1-stage	2-stage	1-stage	2-stage	1-stage	2-stage	1-stage	2-stage
D1	43.815		66.675		98.425		125.73		177.8	
D2	3.4		5.2		5.6		7.2		10.5	
D3	h6	12.7	12.7	12.7	19.05	19.05	25.4	25.4	38.1	38.1
D4	h6	22	38.1	38.1	73.025	73.025	55.55	55.55	114.3	114.3
D5	17		17		30		35		55	
D6	M4X0.7P		M4X0.7P		M6X1P		M10X1.5P		M16X2P	
L1	41.91		57.15		82.55		106.68		146.05	
L2	31.75		31.75		38.1		50.8		63.5	
L3	1.6		1.6		1.6		1.6		3.2	
L4	1		1		3.5		1.5		5.5	
L5	19.05		19.05		25.4		31.75		38.1	
L6	3.788		3.788		3.807		5.715		8.563	
L7	6.35		9.525		9.525		12.7		19.05	
L9	4.5		4.5		5		7.5		12	
L10	10		10		16.5		22		36	
L11	53.4	68.4	67.9	87.9	77.9	104.4	111.4	147.4	127.3	174.8
L12	78.4	93.4	97.4	117.4	117.9	144.4	162.4	198.4	184.3	231.8
B1	h9	3.175	3.175	3.175	4.763	4.763	6.35	6.35	9.525	9.525
H1	14.125		14.125		21.163		28.2		42.275	

(1) Dimensions are related to motor interface. Please contact APEX for details.

PD / PDR Gearbox Performance

Model No.	Stages	Ratio ⁽¹⁾	Type	PD 053	PD 064	PD 090	PD 110	
				PDR 053	PDR 064	PDR 090	PDR 110	
Nominal Output Torque T_{2N}	1	3	All	16	42	110	217	
		4		16	42	113	223	
		5		15	40	118	220	
		7		12	35	96	198	
		10		10	27	68	155	
	2	15		15	40	109	213	
		16		16	42	116	228	
		20		16	42	116	230	
		25		15	40	123	228	
		30		15	40	108	212	
		35		12	35	100	206	
		40		16	43	117	232	
		50		15	40	123	228	
		70		12	35	100	206	
		100		10	27	70	162	
Emergency Stop Torque T_{2NOT}	Nm	1,2	3~100	All				3 times T_{2N}
Max. Acceleration Torque T_{2B}	Nm	1,2	3~100	All				$T_{2B} = 60\%$ of T_{2NOT}
No Load Running Torque ⁽⁴⁾	1	3~10	PD	0.05	0.10	0.40	0.80	
			PDR	0.10	0.15	0.45	0.85	
	2	15~100	PD	0.05	0.10	0.30	0.40	
			PDR	0.10	0.15	0.35	0.45	
Backlash ⁽²⁾	1	3~10	PD	≤ 8	≤ 7	≤ 6	≤ 6	
			PDR	≤ 12	≤ 11	≤ 10	≤ 10	
	2	15~100	PD	≤ 10	≤ 9	≤ 8	≤ 8	
			PDR	≤ 14	≤ 13	≤ 12	≤ 12	
Torsional Rigidity	Nm/arcmin	1,2	3~100	All	1.2	3	10.8	16.2
Nominal Input Speed n_{1N}	rpm	1,2	3~100	All	4,500	4,000	3,600	3,600
Max. Input Speed n_{1B}	rpm	1,2	3~100	All	8,000	6,000	6,000	4,800
Max. Radial Load F_{2rB} ⁽³⁾	N	1,2	3~100	All	1,045	880	1,615	3,675
Max. Axial Load F_{2aB} ⁽³⁾	N	1,2	3~100	All	523	440	808	1,838
Max. Tilting Moment M_{2K}	Nm	1,2	3~100	All	22	17	44	140
Operating Temp	°C	1,2	3~100	All	0° C ~ +90° C			
Degree of Gearbox Protection		1,2	3~100	All	IP65			
Lubrication		1,2	3~100	All	Synthetic lubrication grease			
Mounting Position		1,2	3~100	All	All directions			
Running Noise ⁽⁴⁾	dB(A)	1,2	3~100	PD	≤ 60	≤ 62	≤ 64	≤ 66
				PDR	≤ 70	≤ 72	≤ 74	≤ 75
Max. bending moment based on the gearbox input flange M_b ⁽⁵⁾	Nm	1,2	3~100	PD	7	16	31	56
				PDR	4	9	16	25
Efficiency η	%	1	3~10	PD	$\geq 97\%$			
				PDR	$\geq 93\%$			
		2	15~100	PD	$\geq 94\%$			
				PDR	$\geq 90\%$			

(1) Ratio ($i = N_{in} / N_{out}$).

(2) Backlash is measured at 2% of Nominal Output Torque T_{2N} .

(3) Applied to the output shaft center at 100 rpm.

(4) The dB values are measured by gearbox with ratio 10 (1-stage) or ratio 100 (2-stage), no loading at 3,000 RPM or at the respective Nominal Input Speed by bigger model size.

By lower ratio and/or higher RPM, the noise level could be 3 to 5 dB higher.

(5) Max. motor weight* (kg) = $\frac{0.1 \times Mb}{\text{motor length (m)}}$

*with symmetrically distributed motor weight

*with horizontal and stationary mounting

(6) 5 years warranty.

PD Gearbox Inertia

Model No.	PD 053		PD 064		PD 090		PD 110	
Ø ^(A) (C3)	1-stage	2-stage	1-stage	2-stage	1-stage	2-stage	1-stage	2-stage
8	0.10	0.10	0.12	0.10	-	-	-	-
11	0.16	0.16	0.19	0.16	-	-	-	-
14	-	-	0.22	0.20	0.36	0.24	-	-
19	-	-	1.53	1.51	1.70	1.58	2.20	1.73
24	-	-	-	-	2.24	2.12	2.74	2.27
28	-	-	-	-	2.68	2.55	3.17	2.70
32	-	-	-	-	-	-	7.77	7.30
35	-	-	-	-	-	-	10.80	10.30
38	-	-	-	-	-	-	14.00	13.50
42	-	-	-	-	-	-	-	-

PDR Gearbox Inertia

Model No.	PDR 053		PDR 064		PDR 090		PDR 110	
Ø ^(A) (C3)	1-stage	2-stage	1-stage	2-stage	1-stage	2-stage	1-stage	2-stage
8	0.18	0.18	0.36	0.36	-	-	-	-
11	0.20	0.20	0.39	0.39	-	-	-	-
14	-	-	0.43	0.43	1.87	1.87	-	-
19	-	-	1.24	1.24	2.67	2.67	6.80	6.80
24	-	-	-	-	2.97	2.97	7.10	7.10
28	-	-	-	-	3.47	3.47	7.59	7.59
32	-	-	-	-	-	-	10.56	10.56
35	-	-	-	-	-	-	11.97	11.97
38	-	-	-	-	-	-	13.95	13.95
42	-	-	-	-	-	-	-	-

(A) Ø = Input shaft diameter.

Max. Tilting Moment M_{2K}

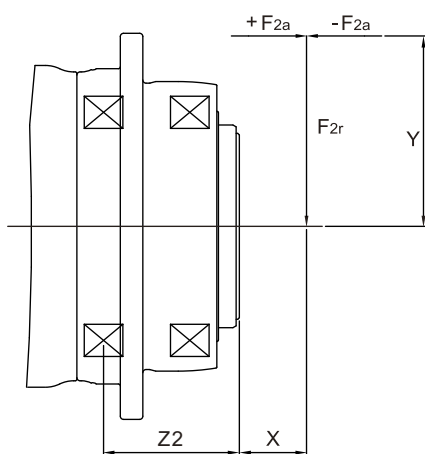

$$M_{2K} = \frac{F_{2a} * Y + F_{2r} * (X+Z2)}{1000}$$

M_{2K} : [Nm]
 F_{2a}, F_{2r} : [N]
 $X, Y, Z2$: [mm]

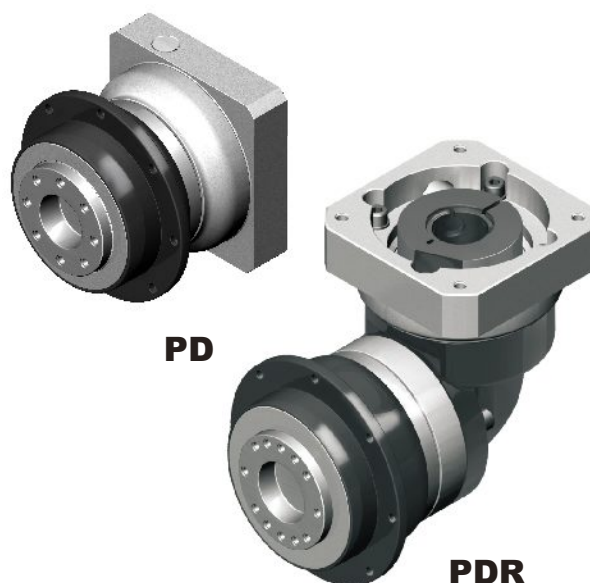

PD / PDR	053	064	090	110
Z2 [mm]	23.8	21.5	30.1	42.1

Note : Applied to the output flange center at 100 rpm.

PD Series Dimension

PT. SINERGI GLOBAL AUTOMASI | sales@negai.co.id | (021) 8267 8558

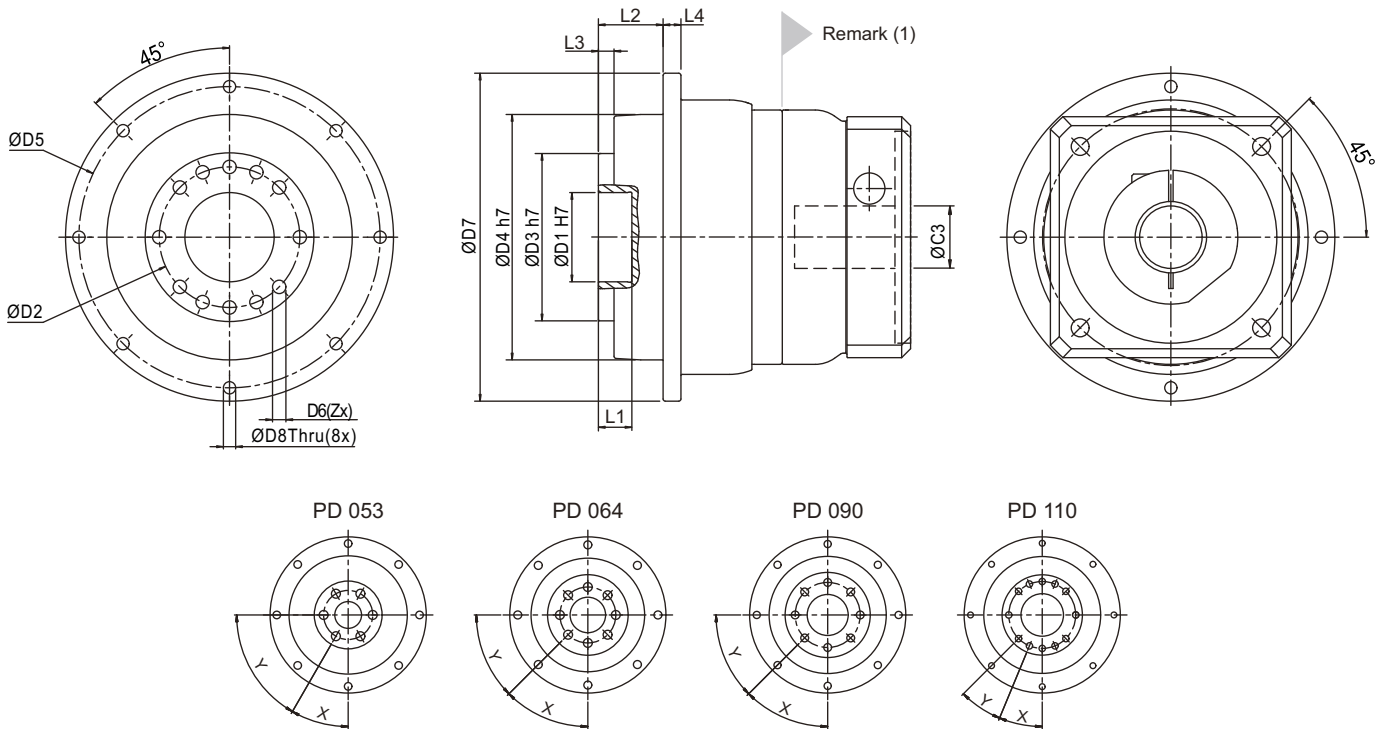

Dimension	PD 053		PD 064		PD 090		PD 110	
	1-stage	2-stage	1-stage	2-stage	1-stage	2-stage	1-stage	2-stage
D1 H7	12		20		31.5		40	
D2	22		31.5		50		63	
D3 h7	28		40		63		75	
D4 h7	53		64		90		110	
D5	64		79		109		135	
D6	M4x0.7Px8L		M5x0.8Px8L		M6x1Px13.5L		M6x1Px13.5L	
D7	70		88		120		147	
D8	3.4		4.5		5.5		5.5	
L1	4		8		15		15	
L2	14.5		19.5		30		29	
L3	3		4		7		7	
L4	5		5		7		8	
X in Degree	30°		45°		45°		22.5°	
Y in Degree	60°		45°		45°		22.5°	
Z	6		8		8		12	

(1) Dimensions are related to motor interface. Please contact APEX for details.

PDR Series Dimension

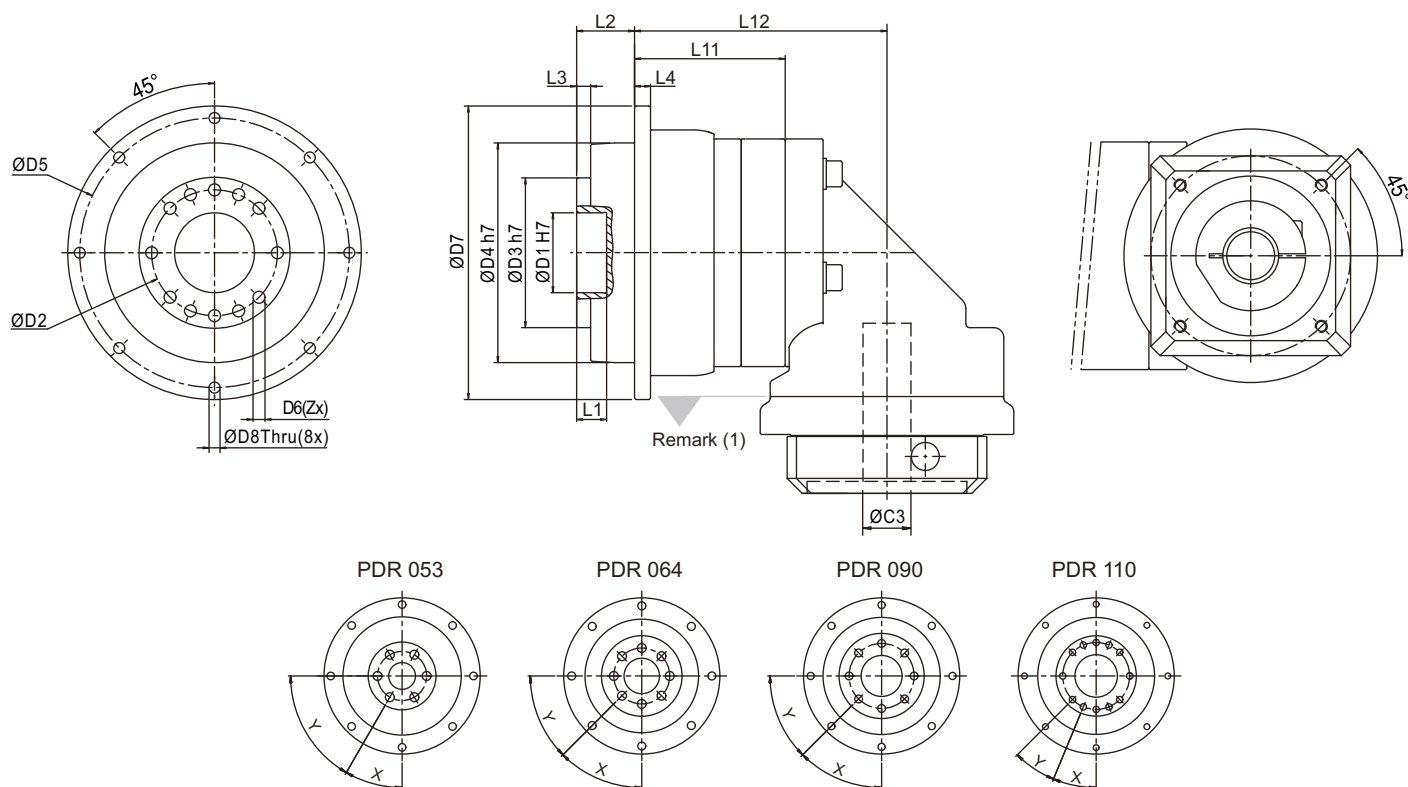

Dimension	PDR 053		PDR 064		PDR 090		PDR 110	
	1-stage	2-stage	1-stage	2-stage	1-stage	2-stage	1-stage	2-stage
D1 H7	12		20		31.5		40	
D2	22		31.5		50		63	
D3 h7	28		40		63		75	
D4 h7	53		64		90		110	
D5	64		79		109		135	
D6	M4x0.7Px8L		M5X0.8Px8L		M6x1Px13.5L		M6X1Px13.5L	
D7	70		88		120		147	
D8	3.4		4.5		5.5		5.5	
L1	4		8		15		15	
L2	14.5		19.5		30		29	
L3	3		4		7		7	
L4	5		5		7		8	
L11	42.8	57.8	39.5	59.5	49.6	76.1	75.4	111.4
L12	67.8	82.8	69	89	89.6	116.1	126.4	162.4
X in Degree	30°		45°		45°		22.5°	
Y in Degree	60°		45°		45°		22.5°	
Z	6		8		8		12	

(1) Dimensions are related to motor interface. Please contact APEX for details.

PL / PLR Gearbox Performance

Model No.	Stages	Ratio ⁽¹⁾	Type	PL 070	PL 090	PL 120	
				PLR 070	PLR 090	PLR 120	
Nominal Output Torque T_{2N}	1	3	All	30	67	107	
		4		39	86	137	
		5		40	89	140	
		7		37	80	128	
		10		27	59	93	
	2	12		31	69	109	
		15		31	70	110	
		16		39	86	137	
		20		39	88	141	
		25		40	89	140	
		30		32	72	111	
		35		36	80	130	
		40		41	92	143	
		50		42	90	143	
		70		37	81	131	
		100		27	59	93	
		Emergency Stop Torque T_{2NOT}		Nm	1,2	3~10	All 3 times T_{2N}
Max. Acceleration Torque T_{2B}	Nm	1,2	3~10	All $T_{2B} = 60\%$ of T_{2NOT}			
No Load Running Torque ⁽⁴⁾	1	3~10	PL	0.10	0.40	0.80	
			PLR	0.15	0.45	0.85	
	2	12~100	PL	0.10	0.30	0.40	
			PLR	0.15	0.35	0.45	
Backlash ⁽²⁾	1	3~10	PL	≤ 7	≤ 6	≤ 6	
			PLR	≤ 11	≤ 10	≤ 10	
	2	12~100	PL	≤ 9	≤ 8	≤ 8	
			PLR	≤ 13	≤ 12	≤ 12	
Torsional Rigidity	Nm/arcmin	1,2	3~100	All	2.2	8	12
Nominal Input Speed n_{1N}	rpm	1,2	3~100	All	4,000	3,600	3,600
Max. Input Speed n_{1B}	rpm	1,2	3~100	All	6,000	6,000	4,800
Max. Radial Load F_{2rB} ⁽³⁾	N	1,2	3~100	All	2,600	3,100	6,550
Max. Axial Load F_{2aB} ⁽³⁾	N	1,2	3~100	All	1,300	1,550	3,275
Operating Temp	°C	1,2	3~100	All	0° C ~ +90° C		
Degree of Gearbox Protection		1,2	3~100	All	IP65		
Lubrication		1,2	3~100	All	Synthetic lubrication grease		
Mounting Position		1,2	3~100	All	All directions		
Running Noise ⁽⁴⁾	dB(A)	1,2	3~100	PL	≤ 62	≤ 64	≤ 66
				PLR	≤ 72	≤ 74	≤ 75
Max. belt tension	N	1,2	3~100	All	560	950	1200
Max. bending moment based on the gearbox input flange M_b ⁽⁵⁾	Nm	2	12~100	PL	19	38	45
		2		PLR	10	17	14
Efficiency η	%	1	3~10	PL	$\geq 97\%$		
				PLR	$\geq 93\%$		
		2	12~100	PL	$\geq 94\%$		
				PLR	$\geq 90\%$		

(1) Ratio ($i = N_{in} / N_{out}$).(2) Backlash is measured at 2% of Nominal Output Torque T_{2N} .

(3) Applied to the output shaft center at 100 rpm.

(4) The dB values are measured by gearbox with ratio 10 (1-stage) or ratio 100 (2-stage), no loading at 3,000 RPM or at the respective Nominal Input Speed by bigger model size.

By lower ratio and/or higher RPM, the noise level could be 3 to 5 dB higher.

(5) Max. motor weight* (kg) = $\frac{0.1 \times M_b}{\text{motor length (m)}}$

*with symmetrically distributed motor weight

*with horizontal and stationary mounting

(6) 5 years warranty.

PL Gearbox Inertia

Model No.	PL 070		PL 090		PL 120	
$\varnothing^{(A)}$ (C3)	1-stage	2-stage	1-stage	2-stage	1-stage	2-stage
8	0.12	0.10	-	-	-	-
11	0.19	0.16	-	-	-	-
14	0.22	0.20	0.36	0.24	-	-
19	1.53	1.51	1.70	1.58	2.20	1.73
24	-	-	2.24	2.12	2.74	2.27
28	-	-	2.68	2.55	3.17	2.70
32	-	-	-	-	7.77	7.30
35	-	-	-	-	10.80	10.30
38	-	-	-	-	14.00	13.50
42	-	-	-	-	-	-

PLR Gearbox Inertia

Model No.	PLR 070		PLR 090		PLR 120	
$\varnothing^{(A)}$ (C3)	1-stage	2-stage	1-stage	2-stage	1-stage	2-stage
8	0.36	0.36	-	-	-	-
11	0.39	0.39	-	-	-	-
14	0.43	0.43	1.87	1.87	-	-
19	1.24	1.24	2.67	2.67	6.80	6.80
24	-	-	2.97	2.97	7.10	7.10
28	-	-	3.47	3.47	7.59	7.59
32	-	-	-	-	10.56	10.56
35	-	-	-	-	11.97	11.97
38	-	-	-	-	13.95	13.95
42	-	-	-	-	-	-

(A) \varnothing = Input shaft diameter.

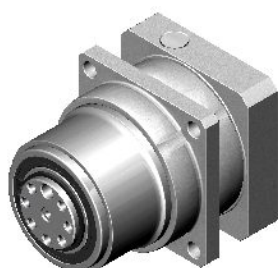

PL



PLR



PL+Pulley



PLR+Pulley

PL Series Dimension

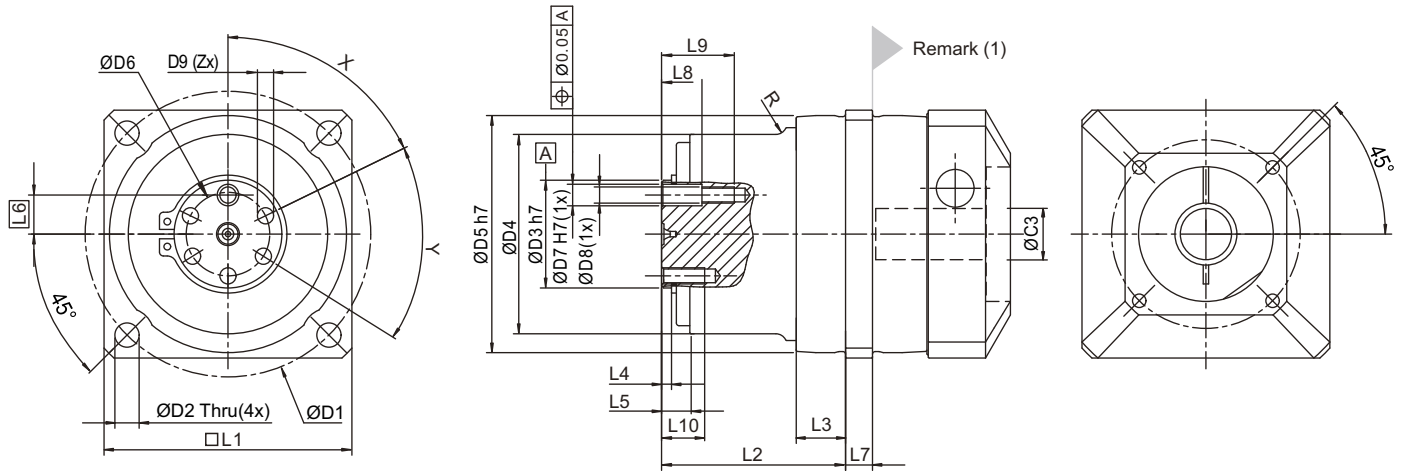

Dimension	PL 070		PL 090		PL 120	
	1-stage	2-stage	1-stage	2-stage	1-stage	2-stage
D1	82		106		144	
D2	6.6		9		13	
D3 h7	25		40		50	
D4	58		74		100	
D5 h7	68		88		118	
D6	18		31		37	
D7 H7	6		8		8	
D8	M5X0.8P		M6X1P		M6X1P	
D9	M5X0.8P		M6X1P		M8X1.25P	
R	-		4		2	
L1	70		92		122	
L2	60.2		68.3		82.2	
L3	12.7		18.3		15.7	
L4	3.8		3.7		4.5	
L5	10		10.5		12.5	
L6	8.8		14.5		18.5	
L7	8		10		12	
L8	10		15		16	
L9	18.5		27		28	
L10	12		16		16	
X in Degree	64°		45°		45°	
Y in Degree	58°		45°		45°	
Z	5		7		7	

(1) Dimensions are related to motor interface. Please contact APEX for details.

PLR Series Dimension

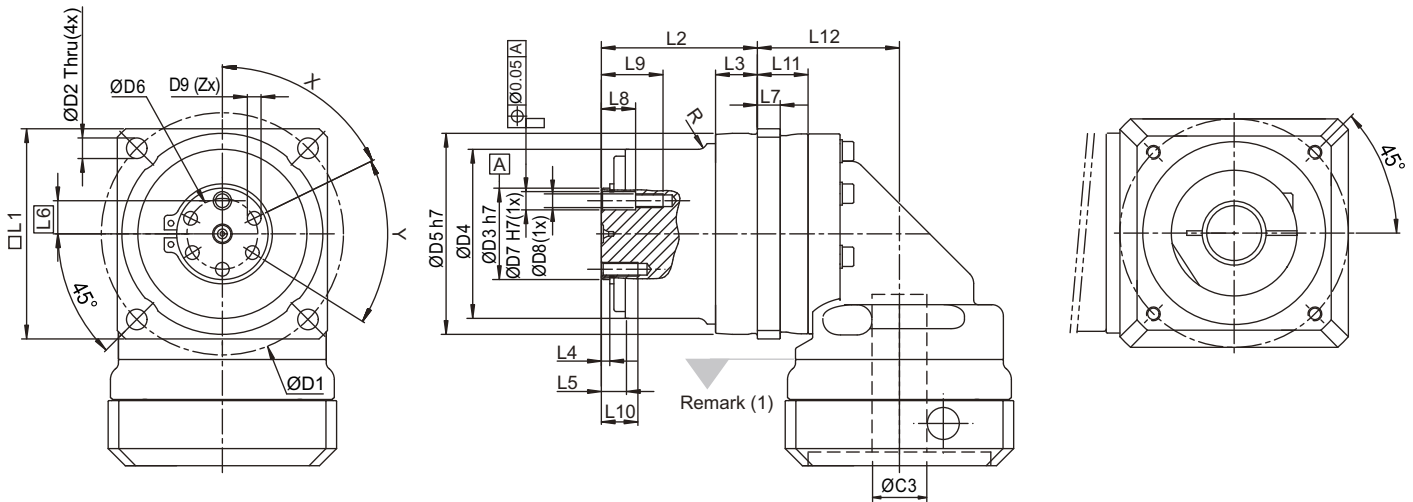

Dimension	PLR 070		PLR 090		PLR 120	
	1-stage	2-stage	1-stage	2-stage	1-stage	2-stage
D1	82		106		144	
D2	6.6		9		13	
D3 h7	25		40		50	
D4	58		74		100	
D5 h7	68		88		118	
D6	18		31		37	
D7 H7	6		8		8	
D8	M5X0.8P		M6X1P		M6X1P	
D9	M5X0.8P		M6X1P		M8X1.25P	
R	-		4		2	
L1	70		92		122	
L2	60.2		68.3		82.2	
L3	12.7		18.3		15.7	
L4	3.8		3.7		4.5	
L5	10		10.5		12.5	
L6	8.8		14.5		18.5	
L7	8		10		12	
L8	10		15		16	
L9	18.5		27		28	
L10	12		16		16	
L11	16.8	36.8	22.2	48.9	34.8	71.1
L12	46.3	66.3	62.2	88.9	85.8	122.1
X in Degree	64°		45°		45°	
Y in Degree	58°		45°		45°	
Z	5		7		7	

(1) Dimensions are related to motor interface. Please contact APEX for details.

PL+PULLEY Dimension

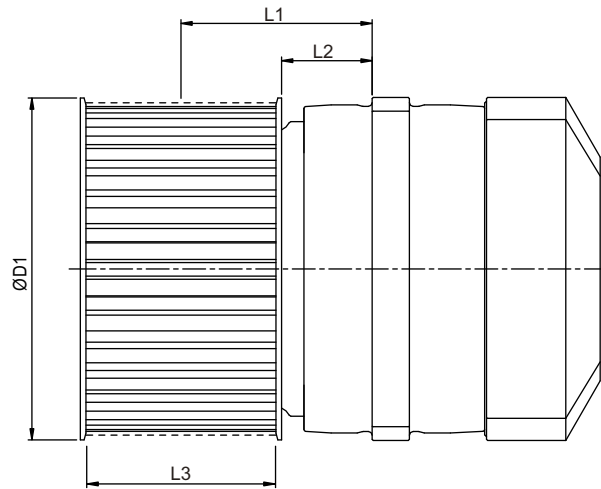

Reducer	Belt Pulley	D1	L1	L2	L3	Pitch P	No.of Teeth Z	Circumference Z*P	Intertia J	Mass m
						mm		mm/rotation	kgcm ²	kg
PL 070 PLR 070	AT05-W50-T43	71	41.8	14.8	51	5	43	215	4.68	0.57
	HTD 5M-W50-T44	72.9	41.8	14.8	51	5	44	220	5.58	0.65
	5GT-W50-T44	72.9	41.8	14.8	51	5	44	220	5.58	0.65
PL 090 PLR 090	AT10-W50-T28	91.7	51.3	24.3	51	10	28	280	14.07	1.00
	HTD 8M-W50-T36	98.4	51.3	24.3	51	8	36	288	17.78	1.18
	8YU-W50-T36	98.4	51.3	24.3	51	8	36	288	17.78	1.18
PL 120 PLR 120	AT20-W75-T19	124.6	57.7	17.7	76	20	19	380	69.55	2.71
	HTD 14M-W75-T28	137	57.7	17.7	76	14	28	392	87.83	3.20

PULLEY ORDERING CODE

PUL070⁽¹⁾ — AT05⁽²⁾ — B⁽³⁾

Pulley size corresponds to gearbox size:

PUL 070: PL 070, PLR 070

PUL 090: PL 090, PLR 090

PUL 120: PL 120, PLR 120

**Ordering Example : PUL 070 - AT05 - B
PUL 090 - 8YU - N**

(1) Pulley size.

(2) Pulley specification.

(3) Pulley appearance. B = Manganese phosphate blackening (Standard)

N = Nickel plating

Selection of the optimum gearbox

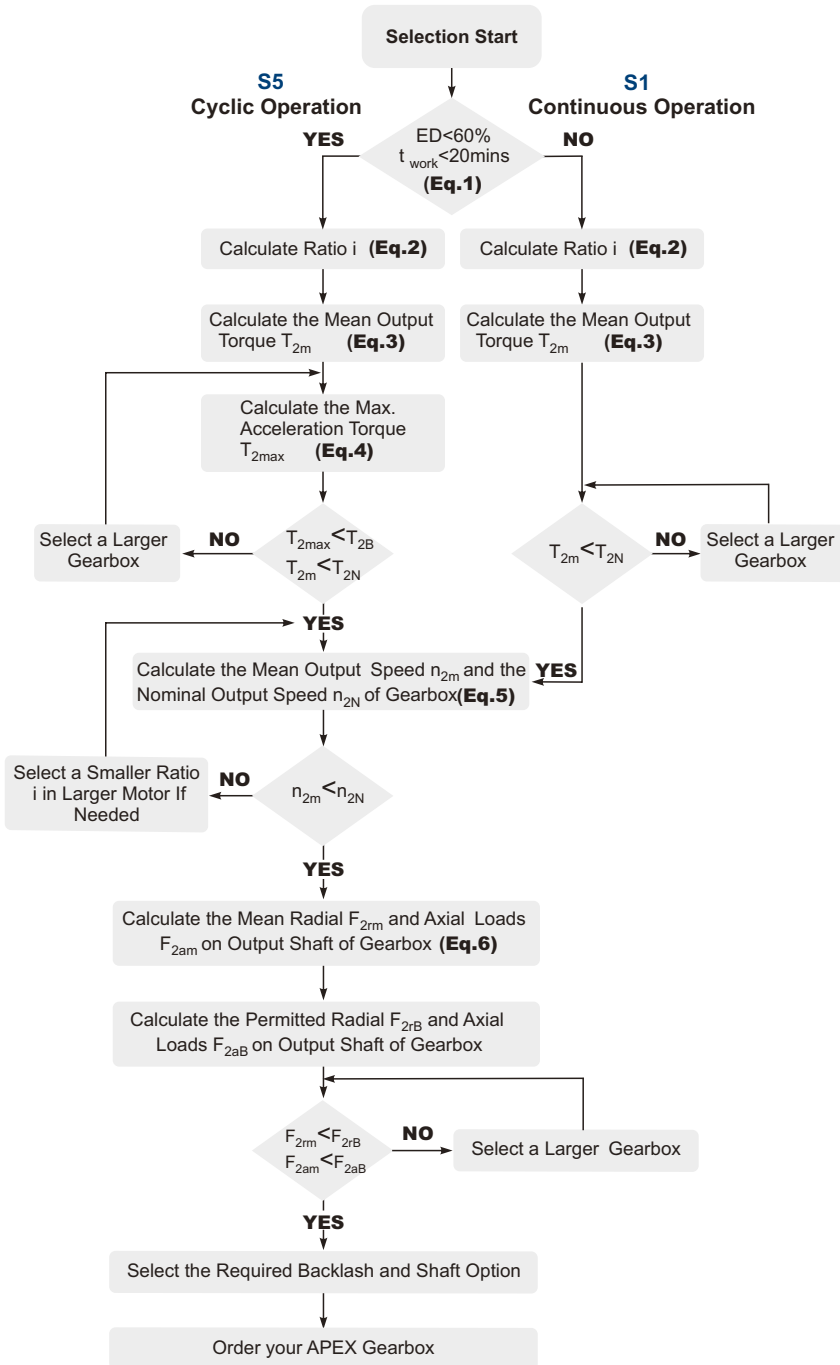

Recommended (for S5 Cycle Operation)

The general design is given for

$$\frac{J_L}{i^2} \leq 4 \times J_m$$

The optimal design is given for

$$\frac{J_L}{i^2} \cong J_m$$

J_L Load Inertia

J_m Motor Inertia

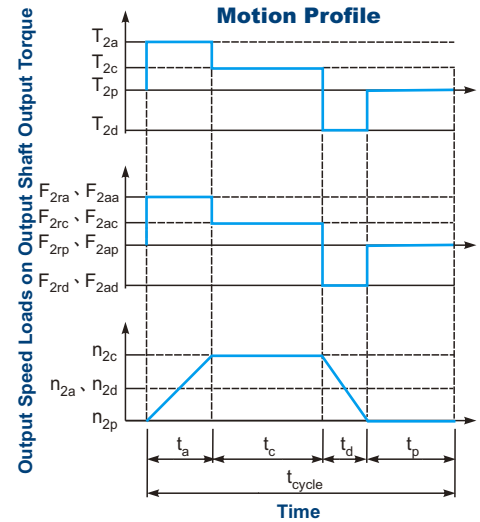

$$1. ED = \frac{t_a + t_c + t_d}{t_{cycle}} \times 100\%, t_{work} = t_a + t_c + t_d$$

Index : a. Acceleration, c. Constant, d. Deceleration, p. Pause (Eq.1)

$$2. i \cong \frac{n_m}{n_{work}}$$

n_m Output Speed of the Motor

n_{work} Working Speed (Eq.2)

$$3. T_{2m} = 3 \sqrt{\frac{n_{2a} \times t_a \times T_{2aa}^3 + n_{2c} \times t_c \times T_{2ac}^3 + n_{2d} \times t_d \times T_{2ad}^3}{n_{2a} \times t_a + n_{2c} \times t_c + n_{2d} \times t_d}}$$

$$4. T_{2max} = T_{mB} \times i \times K_s \times \eta$$

where K_s is

K_s	No. of Cycles / hr
1.0	0 ~ 1,000
1.1	1,000 ~ 1,500
1.3	1,500 ~ 2,000
1.6	2,000 ~ 3,000
1.8	3,000 ~ 5,000

T_{mB} Max. Output Torque of the Motor

η Efficiency of the Gearbox (Eq.4)

$$5. n_{2a} = n_{2d} = \frac{1}{2} \times n_{2c}$$

$$n_{2m} = \frac{n_{2a} \times t_a + n_{2c} \times t_c + n_{2d} \times t_d}{t_a + t_c + t_d}$$

$$n_{2N} = \frac{n_{1N}}{i} \quad (Eq.5)$$

$$6. F_{2rm} = 3 \sqrt{\frac{n_{2a} \times t_a \times F_{2ra}^3 + n_{2c} \times t_c \times F_{2rc}^3 + n_{2d} \times t_d \times F_{2rd}^3}{n_{2a} \times t_a + n_{2c} \times t_c + n_{2d} \times t_d}}$$

$$F_{2am} = 3 \sqrt{\frac{n_{2a} \times t_a \times F_{2aa}^3 + n_{2c} \times t_c \times F_{2ac}^3 + n_{2d} \times t_d \times F_{2ad}^3}{n_{2a} \times t_a + n_{2c} \times t_c + n_{2d} \times t_d}} \quad (Eq.6)$$

Glossary

Emergency Stop Torque T_{2NOT}	Nm	The Emergency Stop Torque is the maximum permitted torque at the output of gearbox. This may happen only occasionally and may not exceed 1,000 times during the whole service life.
Max. Acceleration Torque T_{2B}	Nm	Under the Cyclic Operation (S5), the Max. Acceleration Torque is the maximum torque which can be transmitted only briefly to the output of gearbox up to 1,000 cycles/hr.
No Load Running Torque	Nm	The No Load Running Torque is the min. torque to overcome the internal friction of a gearbox without loading*.
Nominal Input Speed n_{1N}	rpm	The Nominal Input Speed is the permitted input speed of gearbox by the Continuous Operation (S1) while the housing temperature does not exceed 90°C. This value is measured at environment temperature 25°C.
Max. Input Speed n_{1B}	rpm	The Max. Input Speed is the max. permitted input speed of gearbox by the Cyclic operation (S5). This value is measured at environment temperature 25°C and serves as the absolute limit of the gearbox.
Backlash	arcmin	<p>The Backlash is the maximum angular measurement between two teeth of gears when the transverse operation occurs (refer to Diagram 1). The arcmin is the measurement unit for the backlash. One arcmin equals 1/60 degree, symbolized as 1'.</p> <p>Diagram 1</p>
Torsional Rigidity	Nm/arcmin	<p>Torsional Rigidity is the quotient ($\Delta T / \Delta \theta$) between the applied torque and resulting torsion angle. This value indicates how much torque is needed on the gearbox to rotate the output shaft for 1 arcmin. The Torsional Rigidity can be determined by Hysteresis Curve.</p> <p>Hysteresis Curve When the input shaft is locked, increase torque at the output slowly up to T_{2B} in both directions and then release the torque gradually. According to the measured torque and torsion angle, a closed curve will be acquired as in the Diagram 2.</p> <p>Diagram 2</p>
Radial Load And Axial Load	N	<p>The permitted radial and axial loads on output shaft of the gearbox depend on the design of the gearbox supporting bearings.</p> <p>F_{2r} Radial Load F_{2a} Axial Load</p>
Efficiency η	%	The transmission efficiency of the gears inside a gearbox (without friction).
Operating Temperature	°C	The Operating Temperature indicates the temperature of gearbox housing.
Degree of Protection		IP code stands for International Protection standard. The IP65 as example: the first IP number stands for protection degree against dust; the second IP number stands for protection against liquid.
Lubrication		APEX uses synthetic lubrication grease. Alternate greases are available, please contact APEX.
Running Noise	dB(A)	The Running Noise is measured depends on gearbox size, the ratio and the speed*. Higher speed usually induces higher noise level, while higher ratio induces lower noise level.
Moment of Inertia J_1	kg.cm ²	The Moment of Inertia J_1 is a measurement of the effort applied to an object to maintain its momentary condition at rest or rotating.
Breakaway Torque	Nm	The Breakaway Torque is the minimum torque to start the rotation from the input side of gearbox. A smaller size or a higher ratio gearbox requests less Breakaway Torque.
Back Driving Torque	Nm	The Back Driving Torque is the minimum torque to start the rotation from the output side of gearbox. A larger size or a higher ratio gearbox requires greater Back Driving Torque.

* This value is measured at environment temperature 25°C and the input speed 3,000 rpm. If the Nominal Input Speed n_{1N} of gearbox is over 3,000 rpm, this value is measured by that specific Nominal Input Speed.